



www.icecompanies.com

Operator & Parts Manual

Rider Auto Scrubber



RS26
RS32

8300005
REV.03 (03-2015)

INTERNATIONAL CLEANING EQUIPMENT



READ OPERATOR MANUAL CAREFULLY!

IMPORTANT: To ensure full warranty protection, please fill out & return your warranty card.

Please fill out at time of installation for future reference.

Model No. _____

Serial No. _____

Machine Options _____

Sales Rep. _____

Sales Rep. Phone No. _____

Customer ID Number _____

Installation Date _____

HOW TO ORDER PARTS

Only use ICE Company supplied or equivalent parts. Parts and supplies may be ordered online, by phone, by fax or by mail.

1. Identify the machine model.
2. Identify the machine serial number from the data label.
3. Ensure the proper serial number is used from the parts list.
4. Identify the part number and quantity.
Do not order by page or reference numbers.
5. Provide your name, company name, customer ID number, billing and shipping address, phone number and purchase order number.



PROTECT THE ENVIRONMENT

Please dispose of packaging materials, old machine components such as batteries, hazardous fluids, including antifreeze and oil, in an environmentally safe way according to local waste disposal regulations.



Always remember to recycle.

International Cleaning Equipment

XiangShi Road LiaoBu DongGuan GuangDong China

Tel: 0769 - 81850061

Fax: 0769 - 81850001

Specifications and parts are subject to change without notice.

TABLE OF CONTENTS

SAFETY PRECAUTIONS.....	4
MACHINE COMPONENTS.....	5-6
MACHINE SETUP & INSTALLATION.....	7
MACHINE OPERATION.....	8
WHILE OPERATING MACHINE.....	9
TANK DRAINING.....	10
BATTERY CHARGING.....	10
PREVENTATIVE MAINTENANCE.....	11
FAULT CODE AND ELIMINATE.....	12
TECHNICAL SPECIFICATION.....	13
PARTS LIST.....	14-39
WEAR AND TEAR PARTS.....	40
WIRING DIAGRAM.....	41

SAFETY PRECAUTIONS

This machine is intended for commercial use. It is designed exclusively to scrub hard floors in an indoor environment and is not constructed for any other use. Only use recommended accessories.

All operators shall read, understand and exercise the following safety precautions:

1. Do not operate machine:

- Unless trained and authorized.
- Unless you have read and understand the operators manual.
- In flammable or explosive areas.
- With brake disabled.
- If not in proper operating condition.

2. Before starting machine:

- Make sure all safety devices are in place and operate properly.
- Check brakes and steering for proper operation.

3. When using machine:

- Go slow on inclines and slippery surfaces.
- Follow all safety guidelines.
- Be very careful when using the machine in reverse.
- Reduce speed when turning.
- Report and fix any damage to machine prior to operating it.
- Never allow children to play on or around.

4. Before leaving or servicing machine:

- Stop on level surface.
- Turn off machine.

5. When servicing machine:

- Read operators manual thoroughly prior to operating or servicing this machine.
- Use manufacturer supplied or approved replacement parts.
- Secure machine with wheel blocks prior to jacking the machine up.
- Use approved jack or hoist to safely elevate the machine.
- Disconnect batteries prior to working on machine.
- Wear gloves when handling batteries or battery cables.

- Avoid any contact with battery acid
- Avoid moving parts. Do not wear loose fitting clothing while servicing machine.

 **WARNING: Batteries emit hydrogen gas. Explosion or fire can result from hydrogen gas. Keep sparks and open flames away! Keep battery compartment open when charging.**

 **WARNING: Flammable materials can cause an explosion or fire. Do not use flammable materials in tanks.**

 **WARNING: Flammable materials or reactive metals can cause explosion or fire. Do not pick up.**

MACHINE COMPONENTS

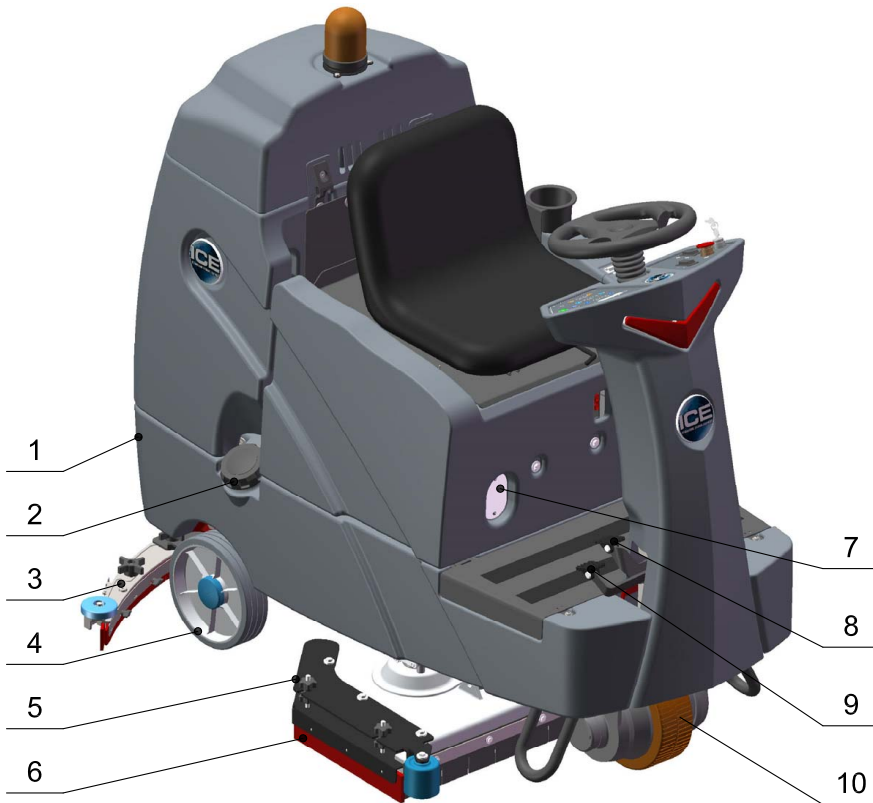

1. Solution tank
2. Hose fill port & Cap
3. Squeegee assembly
4. Wheels, 10 inch
5. Scrub head assembly
6. Side squeegee assembly
7. Watching window, on-board battery charger
8. Brake pedal
9. Propel pedal
10. Front drive wheel

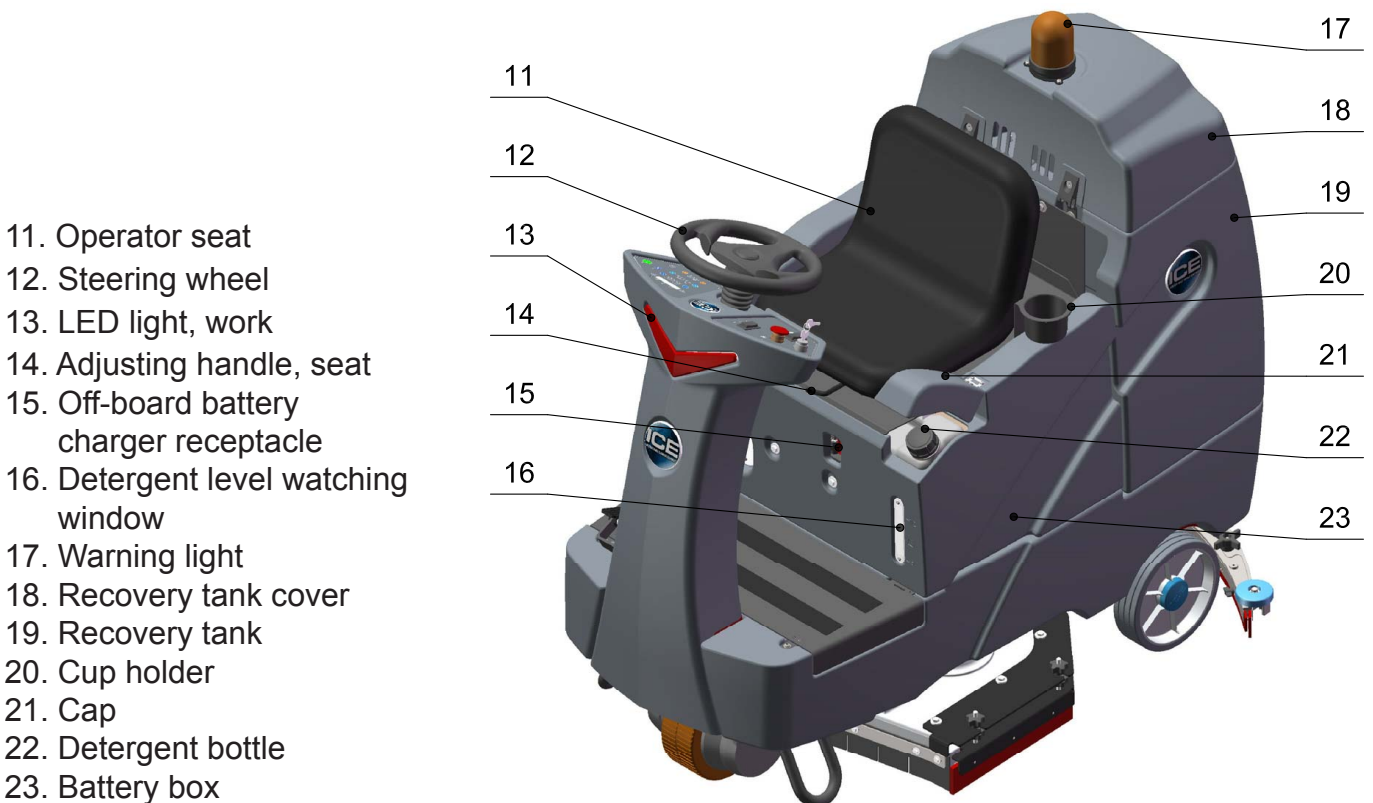

11. Operator seat
12. Steering wheel
13. LED light, work
14. Adjusting handle, seat
15. Off-board battery charger receptacle
16. Detergent level watching window
17. Warning light
18. Recovery tank cover
19. Recovery tank
20. Cup holder
21. Cap
22. Detergent bottle
23. Battery box

MACHINE COMPONENTS



- 24. Directional switch
- 25. Main power key switch
- 26. Emergency stop switch
- 27. Warning light switch
- 28. Contrast control button
- 29. Fault indicator
- 30. LED display screen
- 31. Multi-fault alternate button
- 32. Detergent dosage adjusting buttons & indicators
- 33. Vacuum motor switch & indicator
- 34. 1-Step switch & Indicator
- 35. Solution flow adjusting buttons & indicators
- 36. Horn button & Indicator
- 37. Brush pressure adjusting buttons & indicators
- 38. Drain hose, recovery tank
- 39. Drain hose, solution tank
- 40. Vacuum hose

MACHINE SET UP & INSTALLATION

UNCRATING MACHINE

Be sure and check packing carton for any damage. Immediately report any damage to carrier. Check the contents of package to ensure that the following items are included:

- Machine
 - 4-6V Batteries
 - Squeegee assembly
 - 2-Pad drivers
 - 2-Brushes
1. Uncrate the wooden box, place the top board on the edge of pallet, lie in the front of the machine, as below shown.



WARNING: Do not operate machine unless you have read & understood this manual.

2. Install batteries.(see *INSTALLING BATTERIES*)
3. Turn on the Main power key switch (machine components, #25), make sure the Squeegee assembly (machine components, #3) and the Scrub head assembly (machine components, #5) is off the floor.
4. Sit in the Operator seat (machine components, #11), hold the Steering wheel (machine components, #12), press the Propel pedal (machine components, #9) and driving slowly the machine down from the slope.

INSTALLING BATTERIES



WARNING: Batteries emit hydrogen gas. Explosion or fire can result from hydrogen gas.Keep sparks and open flames away! Keep battery compartment open when charging.

Recommended battery spec:
4-6V, 260AH@20HR deep cycle batteries.

Max. batteries dimensions :

- 300mm (L) X 180mm (W) X 290mm (H)
1. Turn the Main power key switch off.
 2. Remove the Operator seat & the Battery box (machine components, #23).

3. Carefully place the batteries into the compartment as shown in figure below. Place the battery brace at the rear of the batteries.

NOTE: Do not drop the batteries into the compartment!

4. Connect battery cables to posts in numbered order as shown in drawing below.

NOTE: RED to POSITIVE and BLACK to NEGATIVE.

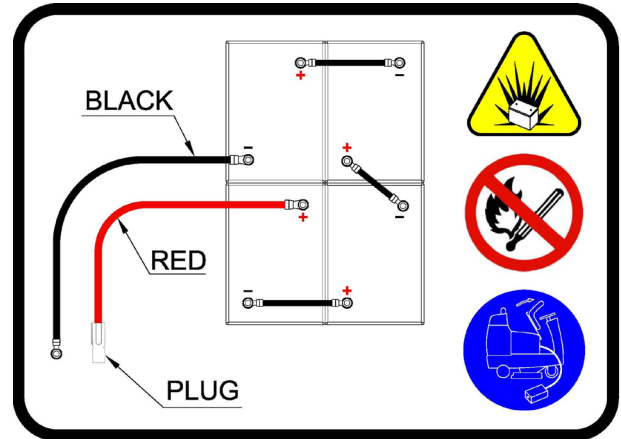

5. Reinstall the Operator seat and the Battery box.

MACHINE SET UP

INSTALLING BRUSHES OR PADS

1. Turn off the 1-Step switch (machine components, #34) and raise the Scrub head assembly off the floor, then stop machine on the level surface, remove the key and ensure the machine is turned off.
2. If using the pad driver, first attach the appropriate pad to the pad driver surface.
3. Align the pad driver or brush under the motor hub and push it upward to engage.



4. To remove the pad driver or brush, raise the scrub head and remove the Side squeegee assembly (machine components, #6), push the edge of brush downward.

MOUNTING THE SQUEEGEE ASSEMBLY

1. Turn off the 1-Step switch and raise the Squeegee assembly off the floor.
2. Mount the squeegee assembly to the squeegee pivot bracket. make sure the knobs are completely seated into the slots before securing knobs.
3. Connect the Vacuum hose (machine components, #40) to the squeegee assembly. Loop the hose by using the hose clip provided.
4. Check the squeegee blades for proper adjustment.

FILLING THE SOLUTION TANK

The machine is equipped with a Hose fill-port (machine components, #2) at the side of the machine, and a bucket fill-port located under the recovery tank.

NOTE: Before accessing the bucket fill-port make sure that the recovery tank is empty. When filling the solution tank with a bucket, make sure that the bucket is clean. Do not use the same bucket for filling and draining the machine.



WARNING: Do not put any flammable materials into solution tank. this can cause an explosion or a fire.

FILLING THE DETERGENT BOTTLE

The machine is equipped with a 6 liters Detergent bottle (machine components, #22). Open the Cap (machine components, #21) you can fill detergent, and watch the liquid level on the Detergent level watching window (machine components, #16).

The ratio of water and detergent is 0~5%, you can adjust this ratio via pressing the Detergent dosage adjusting buttons (machine components, #32).

NOTE: Only use recommended cleaning chemicals. Contact your janitorial supply distributor for recommendations on proper chemicals.

MACHINE OPERATION



WARNING: Do not operate machine unless you have read and understand this manual.

PRE-OPERATION CHECKS

1. Check the tank cover seals for damage.
2. Drain the recovery tank, check the vacuum fan inlet filter, clean them if necessary.
3. Check the vacuum hose for debris or blockage.
4. Check the squeegees for damage, wear and for deflection adjustment.
5. Check whether Pad/Brush is installed properly .
6. Check the brakes and steering for proper operation.

OPERATION THE MACHINE

1. Sit in the Operator seat, adjusting the seat to comfortable place by pushing the Seat adjustment handle (machine components, #14).
NOTE: The machine will not travel unless the operator is sitting in the operator seat.
2. Turn on the Main power key switch. Check the LED display screen (machine components, #30) , if there are fault codes and the Fault indicator (machine components, #29) is blink, please Do Not operation the machine unless the faults have been eliminated (please see *FAULT CODES AND ELIMINATE* section).
3. Select the preferred settings by pressing the Brush pressure adjusting buttons (machine components, #37) , Solution flow adjusting buttons (machine components, #35) and Detergent dosage adjusting buttons.
NOTE: Use the minimal pressure and flow as possible.
4. Turn on the 1-Step switch, the Scrub head assembly and the Squeegee assembly will lower down automatically, all the presetting functions will turn on.
5. The machine can scrub in both forward and backward, place the Directional switch (machine components, #24) in the forward direction is to move forward, backward is to move backward. The horn will sound and the squeegee will raise automatically (the vacuum motor will turn off after a short delay) when drive machine backwards. This is to prevents damaging the squeegee.
NOTE: Go slow when drive machine backwards.

6. Press the Propel pedal, the machine start scrubbing, the speed can be adjusted by controlling the force of foot stepping, light is slow, heavy is fast.

NOTE: Go slow on inclines and slippery surfaces.

7. To stop scrubbing, turn off the 1-Step switch, the scrub head will raise automatically, the squeegee will also raise after a short delay (the vacuum indicator flashing), please keep moving until the dirty water is picked up, and then release the propel pedal and stop scrubbing.
8. Turn off the Main power key switch.

BRAKE DEVICE

The machine is driven by the Front drive wheel (machine components, #10), that is equipped with a brake device. When you release the Propel pedal, the machine will stop travel, the park brake will engage after a short delay.

The machine is equipped with a Brake pedal (machine components, #8), that can be used to control the machine if quicker stopping is needed or if operating on an incline.

EMERGENCY STOP BUTTON

The machine is equipped with an Emergency stop button (machine components, #26), please push it if an emergency, that will shut off all power of machine and brake immediately.

To restart the machine, please reset the Emergency stop button, and turn off the Main power key switch, then turn on key switch.

NOTE: Please hold the steering wheel when emergency stop.

WHILE OPERATING MACHINE



WARNING: Fire Or Explosion Hazard. Do Not Pick Up Flammable Materials Or Reactive Metals.

1. Go slow on inclines and slippery surfaces, go slow when turn and reverse. Do not operate the machine on inclines that exceed 7% (4°).
2. Drive machine in a straight path as possible, avoid turning the Steering wheel too sharply when machine is in motion. avoid sudden turns except emergencies.
3. Do not keep the machine in the same position with pad / brush spinning, keep the machine moving to prevent damage to floor finish.
4. If the squeegee assembly leaves streaks on the floor, raise the squeegee off the floor and wipe

- the blades down with a damp cloth. Pre-sweep the area to prevent leaving streaks on the floor.
5. To obtain the optimum cleaning performance, you can adjust the brush pressure, solution flow and detergent dosage as your required. If poor picking up water performance is observed, please stop scrubbing and check the squeegee blade, adjust or replace if necessary.
6. If the dirty water path exceed the width of squeegee, please adjust the side squeegee assembly.
7. Pour a recommended defoamer into the recovery tank if excessive foam appears.



WARNING: The foam do not activate water level switch, excessive foam may result in vacuum motor damage.

8. Press the Horn button (machine components, #36) to alert if necessary.
9. The machine is equipped with a Warning light (machine components, #17), you can select turn ON or OFF by the Warning light switch (machine components, #27).
10. If there is a fault code F11 (Bat. very low) on the LED display screen, the machine will stop scrubbing and alarm, please drive the machine to charging.
11. If there is a fault code F8 (RecTank Full) on the LED display screen, the vacuum motor will stop working and alarm, please drive the machine to drain water.
If there is a fault code F9 (SolTank Empty) on the LED display screen, the Detergent system will stop working and alarm, please fill the solution tank.
12. If there are other fault codes on the LED display screen, please turn off the machine, eliminate the fault (please see FAULT CODES AND ELIMINATE section), then restart machine.
13. For heavily soiled areas, please use DOUBLE SCRUBBING mode.
The first time: Turn on the 1-Step switch, then press the Vacuum motor switch (machine components, #33), its indicator will turn off and the squeegee will raise automatically, then start to scrubbing this areas without picking up water.
The second time: turn on the Vacuum motor switch, the squeegee will lower down automatically, and then start to scrubbing and picking up water.
14. If you only want to pick up water needn't scrubbing, Turn on the Vacuum motor switch (squeegee will lower down) and turn off the 1-Step switch (if it is ON), the scrub head will raise and then start to working.

TANK DRAINING

DRAINING THE RECOVERY TANK

Any time scrubbing is completed, or when refilling solution tank, the recovery tank should be drained and cleaned.

⚠ WARNING: If the recovery tank is not drained when the solution tank has been refilled, foam or water may enter the float shut-off screen and cause damage to the vacuum motor.

1. While holding the Recovery tank drain hose (machine components, #38) upward, remove the cap and lower hose to drain.
2. Open the Recovery tank cover (machine components, #18) and rinse out the tank. Use a rag to remove any excess dirt. Clean the vacuum fan inlet filter located in the recovery tank .

DRAINING THE SOLUTION TANK

Any time scrubbing operation is completed, the solution tank should be drained and cleaned.

1. While holding the Solution tank drain hose (machine components, #39) upward, remove the cap and lower hose to drain.
2. Rinse the solution tank with clean water after every use. This will help prevent chemical buildup and clogging of the solution lines.

BATTERY CHARGING

⚠ WARNING: Fire Or Explosion Hazard. Batteries Emit Hydrogen Gas. Keep Sparks and Open Flame Away. Keep Battery Compartment Propped Open When Charging.

Use only approved chargers with the following specifications:

- Automatic shut off circuit
- Deep cycle charging
- Output current of 20-30 Amps
- Output voltage of 24 volts

ON-BOARD BATTERY CHARGER

As standard configuration, the machine is equipped with the On-board battery charger. The settings of On-board battery charger had been set for the recommended batteries type.

⚠ WARNING: The On-board battery charger setting's change are to be completed by authorized service centers only. Failure to properly set will result in the batteries or charger damage.

1. Transport the machine to a well ventilated area.
2. Turn the machine off.
3. If charging wet (lead acid) batteries check the fluid level before charging.
4. Prop up the Operator seat by the support stand for ventilation.
5. Connect the charger's AC power supply cord to a properly grounded receptable.
6. The charger will automatically begin to charge, you can watching the charging status on the window (machine components, #7), once the charging cycle begins, the indicator lights will progress from red, yellow to green. when the green indicator light comes on, the charging cycle is done. Unplug the charger cord.

NOTE: The machine will can not operate when charging.

OFF-BOARD BATTERY CHARGER (OPTION)

1. Place charger and machine in a well ventilated area.
2. Turn the machine off.
3. If charging wet (lead acid) batteries check the fluid level before charging.
4. Prop up the Operator seat by the support stand for ventilation.
5. Connect the charger's AC power supply cord to a properly grounded receptable.
6. Connect the charger's DC cord into the Off-board battery charger receptacle (machine components, #15).
7. The charger will automatically begin to charge and will autoatically shut off once the batteries are fully charged.
8. Upon completion of charging, disconnect the AC power supply cord first, and then disconnect the charger from the machine.

PREVENTATIVE MAINTENANCE

 **WARNING:** Before performing any maintenance on the machine, be sure that the power is turned off, or the batteries are disconnected!

 **WARNING:** Repairs are to be completed by Authorized service centers only. Any repairs completed by unauthorized persons will void the warranty.

DAILY MAINTENANCE

1. Remove pad driver/ brush and clean with approved cleaner.
2. Drain recovery and solution tanks completely and rinse out with clean water. Visually check the recovery tank for debris and clean out as necessary.
3. Raise the squeegee assembly off floor and wipe it down with a damp towel. Be sure to store the squeegee in the up position.
4. Remove the vacuum fan inlet filter and rinse it out with clean water.
5. Clean machine with an approved cleaner and a damp towel.
6. Recharge the batteries.
7. Check the condition of the squeegee blade wiping edge, rotate blade if worn.

MONTHLY MAINTENANCE

1. Clean the battery tops to prevent corrosion.
2. Check for loose battery cable connections.
3. Inspect and clean the recovery tank cover seal. Replace it if damaged.
4. Lubricate all grease points and pivot points with silicon spray and approved grease.
5. Check the machine for loose nuts and bolts.
6. Check the machine for leaks.

MOTOR MAINTENANCE

1. Contact your local Distributor for any motor maintenance.
2. Motor should have the brushes checked every 250 hours. Brushes should be replaced when they are worn to a length of 10 mm or less.

BATTERY MAINTENANCE

 **WARNING:** Batteries emit hydrogen gas and an explosion or fire can result. Keep sparks and fire away from batteries at all times.

 **WARNING:** Whenever servicing batteries, be sure to wear protective gloves. Avoid contact with battery acid at all times.

NOTE: For the best machine performance, keep batteries charged at all times. Do not let them sit in a discharged condition.

1. Always follow the battery charging directions as outlined in the BATTERY CHARGING section of this manual.
2. Keep battery tops and terminals free from corrosion. A strong solution of baking soda and water is the best way to keep the batteries corrosion free. DO NOT ALLOW THE BAKING SODA / WATER SOLUTION TO ENTER THE BATTERY CELLS.
3. Use a wire brush with the baking soda solution to properly clean the battery posts and connections.
4. Check battery connections for wear and loose terminals. replace if necessary.

MACHINE STORAGE

1. Always store the machine indoors.
2. Always store the machine in a dry area.
3. Always store the machine in its upright position.
4. Always store the machine with the pad driver/ brush raised off the floor.
5. Always store the machine with the squeegee assembly raised off the floor.
6. If storing in an area which may reach freezing temperatures, be sure to drain all fluids from the machine prior to storage. Any damage caused by freezing temperatures will not be covered by the warranty.
7. Drain the recovery tank.
8. Drain the solution tank of all fluid.

OPERATOR MANUAL

FAULT CODE AND ELIMINATE

This machine is equipped with a LED display screen and a red Fault indicator, you can control contrast ratio by Contrast control button (machine components, #28).

The LED screen will display the machine operating hours and the battery level status.

When a fault occurring, there will be fault code and warning message display on the LED screen, and the red indicator will blink continuously accompany an audible alarm.

If there is more than one fault, each fault code can be alternately display by pressing the Alternate button (machine components, #31).

Once fault occurring, please DO NOT continue operate the machine unless the fault are eliminated.

Turn off the machine, then to solve the fault, the fault code will be eliminated when machine restarted.

If the fault is occurred frequently, or the fault can't be eliminated, please contact ICE service.

Refer to the table below to determine the cause and remedy for the fault.

Fault code	Warning message	Fault cause	Remedy
F1	Sit in Seat	Not sit in the seat	Sit in the operator seat
		Seat circuit open	Check circuit or contact ICE service center
F2	Ems active	Emergency stop button be activated	Reset emergency stop button, restart the machine
		circuit open	Check circuit or contact ICE service center
F3	Sqge Stall	Squeegee lifting motor is overload	Restart the machine
		Squeegee lifting components fault	Check squeegee lifting components or contact ICE service center
F4	Act. OverLoad	Scrub head lifting motor is overload	Restart the machine
		Scrub head lifting components fault	Check scrub head lifting components or contact ICE service center
F5	Vac. OverLoad	Vacuum motor overload	1. Turn off the machine, wait a moment, restart machine. 2. If the fault is still exist,contact ICE service center.
F6	Bru. OverLoad	Brush motor overload	
F7	Propel Error	Propel motor overload	
F8	RecTank Full	Recovery tank is full	Drain the recovery tank
		Bad recovery tank water level switch	Replace or contact ICE service center
F9	SolTank Empty	Solution tank is empty	Fill the solution tank
		Bad solution tank water level switch	Replace or contact ICE service center
F10	Bat. Low	Battery is low, below 40%	Charging battery
F11	Bat. Very Low	Battery is low, below 20%	Charging battery
		Bad batteries	Replace batteries
F12	Brake Open	Brake circuit open	Contact ICE service center
F13	Accel. SRO	stepping the propel pedal when starting machine	Release the propel pedal when turn on the machine
F14	Brake Short	Brake device overload	Restart machine
		Bad brake device	Contact ICE service center
F15	No Brush	No brush or brush installed improperly	Install brush properly

TECHNICAL SPECIFICATIONS

MODEL	RS26	RS32
DIMENSIONS L × W × H	1565 × 815 × 1440 mm	1565 × 950 × 1440 mm
WEIGHT	280 Kg	290 Kg
WEIGHT WITH BATTERIES	400 Kg	410 Kg
RECOVERY TANK CAPACITY	110 L /29 Gal	
SOLUTION TANK CAPACITY	110 L /29 Gal	
SQUEEGEE WIDTH	860 mm / 33.8 in	1030 mm /40 in
CLEANING PATH WIDTH	650 mm /26 in	800 mm /32 in
PRODUCTIVITY RATE (IN THEORY)	4300 m ² h	5200 m ² h
TRAVEL SPEED (TRANSPORT)	6.5 Km/h	
MINIMUM ALSLE TURN	1800mm	1900mm
PAD/BRUSH PRESSURE	35Kg / 55Kg / 75Kg	
SOLUTION FLOW	0 ~ 2.7 L/ Min	
DRIVE WHEEL	24VDC 850W	
BRUSH MOTOR	24VDC 450W × 2	
VACUUM MOTOR	24VDC 450W	
BATTERIES	4 × 6V,260AH@20 hr	
RUN TIME PER CHARGE	3~3.5 Hours	
VOLTAGE DC	24V	
DECIBEL RATING AT OPERATOR'S EAR, INDOORS	68 dB(A)	
GRADE LEVEL, MAX	Scrubbing: 4°/7%	Transporting (empty):10°/17.5%

MAIN FRAME GROUP

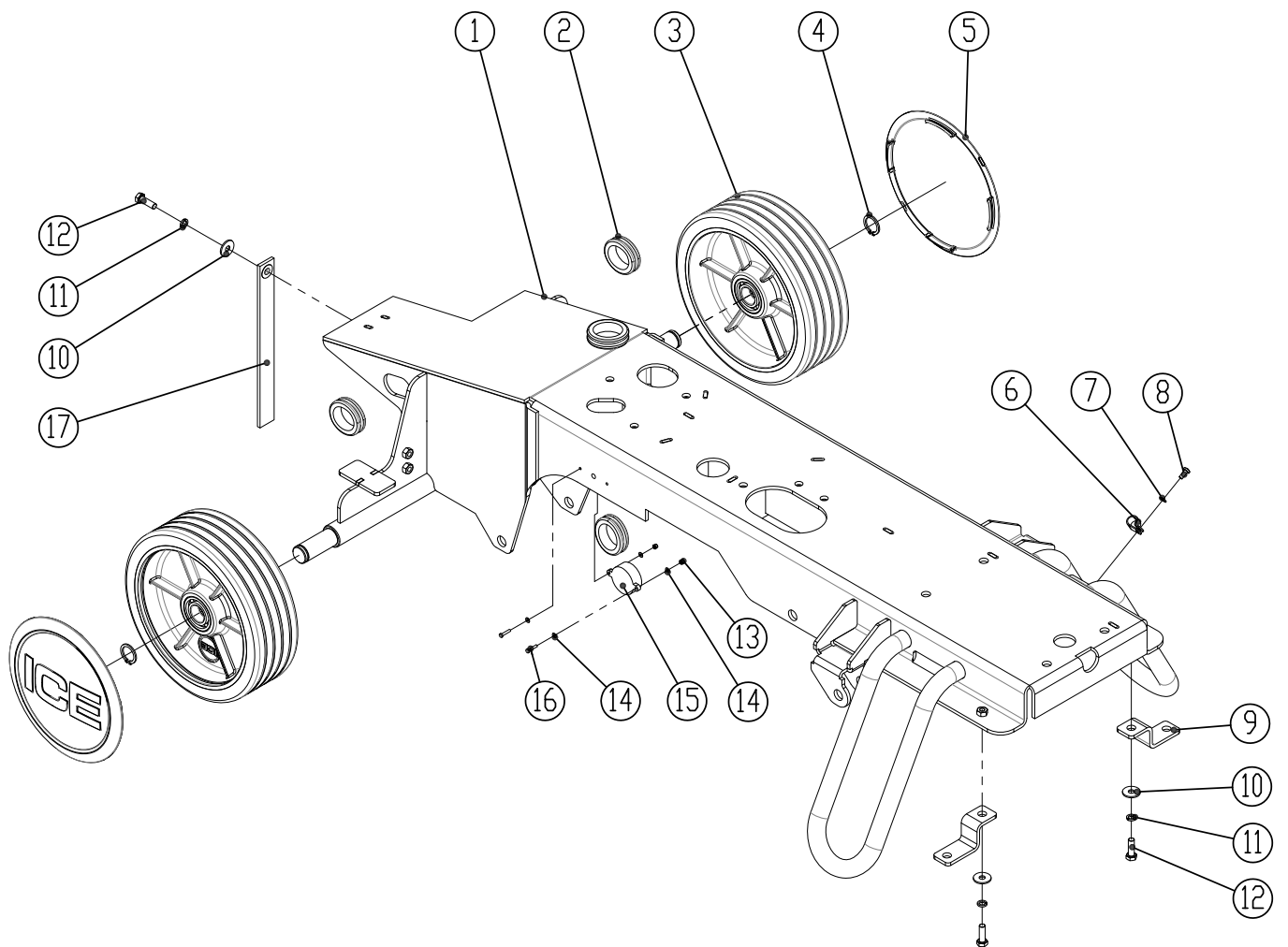

MAIN FRAME GROUP

DIA NO.	PART NUMBER	DESCRIPTION	NO REQ'D
1	8310102	MAIN FRAME, WELDED	1
2	8310133	RUBBER GROMMET	4
3	8310119	10" WHEEL	2
4	1436025	RETAINING RING, 25MM	2
5	8310150	WHEEL CAP	2
6	6210131	NYLON, CLAMP	1
7	1421510	FLAT WASHER, M5× ϕ 10×1.0	1
8	1221512	SCREW, PAD HEAD, M5×12	1
9	8310120	BRACKET, STAND	2
10	1421824	FLAT WASHER, M8× ϕ 24×2.0	3
11	1422821	LOCK WASHER M8	3
12	1021825	BOLT, HEX HEAD, M8×25	3
13	1123305	LOCK NUT M3	2
14	1421307	PLAT WASHER, M3× ϕ 7×0.5	4
15	8310708	HORN, 24VDC	1
16	1211316	SCREW, PAD HEAD, M3×16	2
17	8210118	STATIC STRAP	1

STEERING & DRIVE WHEEL GROUP

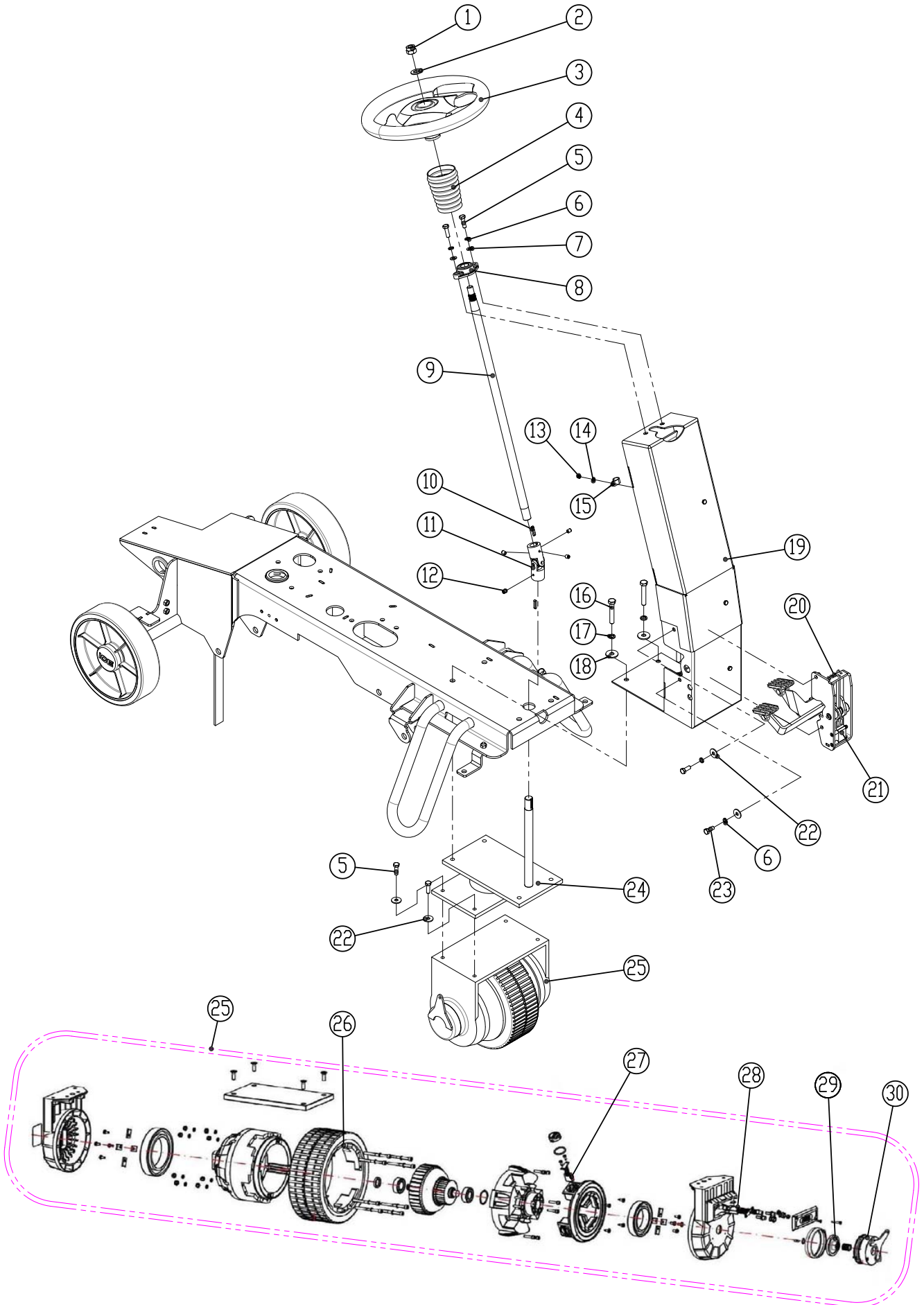

STEERING & DRIVE WHEEL GROUP

DIA NO.	PART NUMBER	DESCRIPTION	NO REQ'D
1	1113014	LOCK NUT, M14	1
2	1421428	FLAT WASHER, M14× ϕ 28×2.0	1
3	8310602	STEERING WHEEL	1
4	8310608	BELLOWS, SHAFT, STEERING	1
5	1021825	BOLT, HEX HEAD, M8×25	6
6	1422821	LOCK WASHER, M8	4
7	1421816	FLAT WASHER, M18× ϕ 16×1.6	2
8	8310609	BEARING, FLANGE	1
9	8310605	SHAFT, STEERING WHEEL	1
10	1654025	KEY, 4.75×4.75×25.4	2
11	8310604	U-JOINT	1
12	1534508	SET SCREW, M5 ×8	4
13	1123507	LOCK NUT, M5	3
14	1421510	FLAT WASHER, M5× ϕ 10×1.0	3
15	6210131	CLAMP, NYLON	3
16	1021060	BOLT, HEX HEAD, M10×60	4
17	1422026	LOCK WASHER, M10	4
18	1421030	FLAT WASHER, M10× ϕ 30×2.5	4
19	8310601	SUPPORT BRACKET, STEERING	1
20	8310430	ACCELERATOR/ BRAKE PEDAL	1
21	8310431	HALL SENSOR WITH CABLE	1
22	1421824	FLAT WASHER, M14× ϕ 24×2.0	6
23	1021820	BOLT, HEX HEAD, M8×20	2
24	8310603	STEER-CONTROL ASSY.	1
25	8310610	DRIVE WHEEL, 24VDC 800W	1
26	8310611	PU TIRE, DRIVER WHEEL	1
27	8310612	ARMATURE BRUSH	4
28	8310613	BRUSHES CONNECTION BOX	2
29	8310615	FRICTION DISC	1
30	8310616	ELECTRICALLY RELEASED BRAKE	1

SOLUTION TANK GROUP

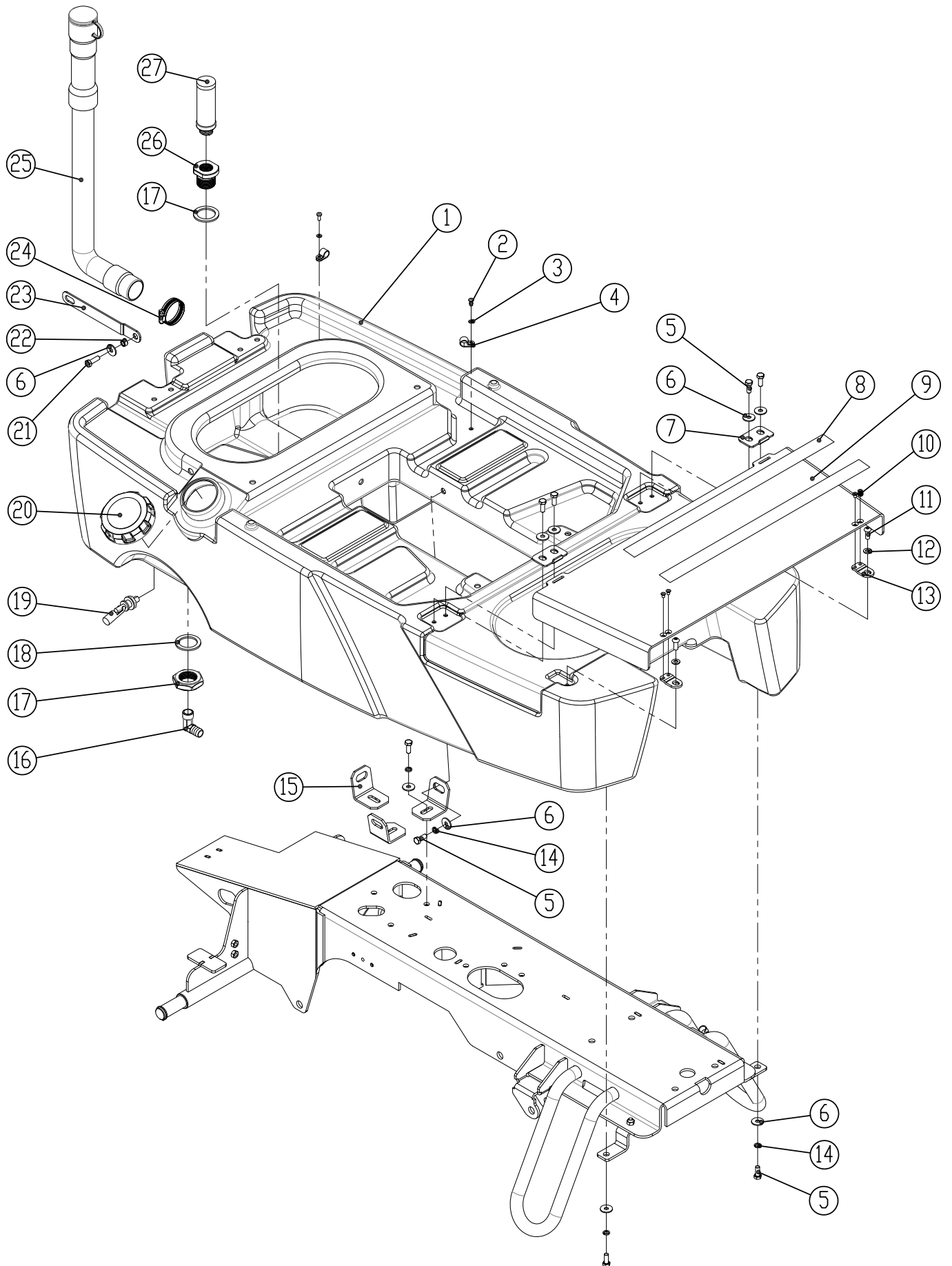

SOLUTION TANK GROUP

DIA NO.	PART NUMBER	DESCRIPTION	NO REQ'D
1	8310101	SOLUTION TANK	1
2	1221512	SCREW, PAD HEAD, M5×12	2
3	1421510	FLAT WASHER, M5× ϕ 10×1.0	2
4	8113009	CLAMP, NYLON	2
5	1021820	BOLT, HEX HEAD, M8×20	12
6	1421824	FLAT WASHER, M8× ϕ 24×2.0	13
7	8310139	PLATE	2
8	8310151	NON-SLIP MAT	2
9	8310132	FOOTREST PLATE	1
10	1222508	SUNK SCREW, M5×8	4
11	1512820	SCREW, HEX SOCKET, M8×20	2
12	1421816	FLAT WASHER, M8× ϕ 16×1.6	2
13	8310140	JUNCTION PLATE	2
14	1422821	LOCK WASHER, M8	8
15	8310130	BRACKET, SOLUTION TANK MNTG	3
16	8310124	ELBOW, G1/2	1
17	8310142	NUT, M36	1
18	8310141	SEALING	2
19	8310238	SENSOR, SOLUTION LEVEL	1
20	8310125	CAP, SOLUTION TANK	1
21	1021825	BOLT, HEX HEAD, M8×25	1
22	8310225	SLEEVE, ϕ 8.1× ϕ 12.7×7.8	1
23	8310224	ARM, RECOVERY TANK SUPPORT	1
24	1962050	CLAMP, 2 INCH	1
25	8011030	HOSE ASSEMBLY	1
26	8310123	ADAPTER, STRAINER ASSY	1
27	8310122	STRAINER ASSY	1

RECOVERY TANK GROUP

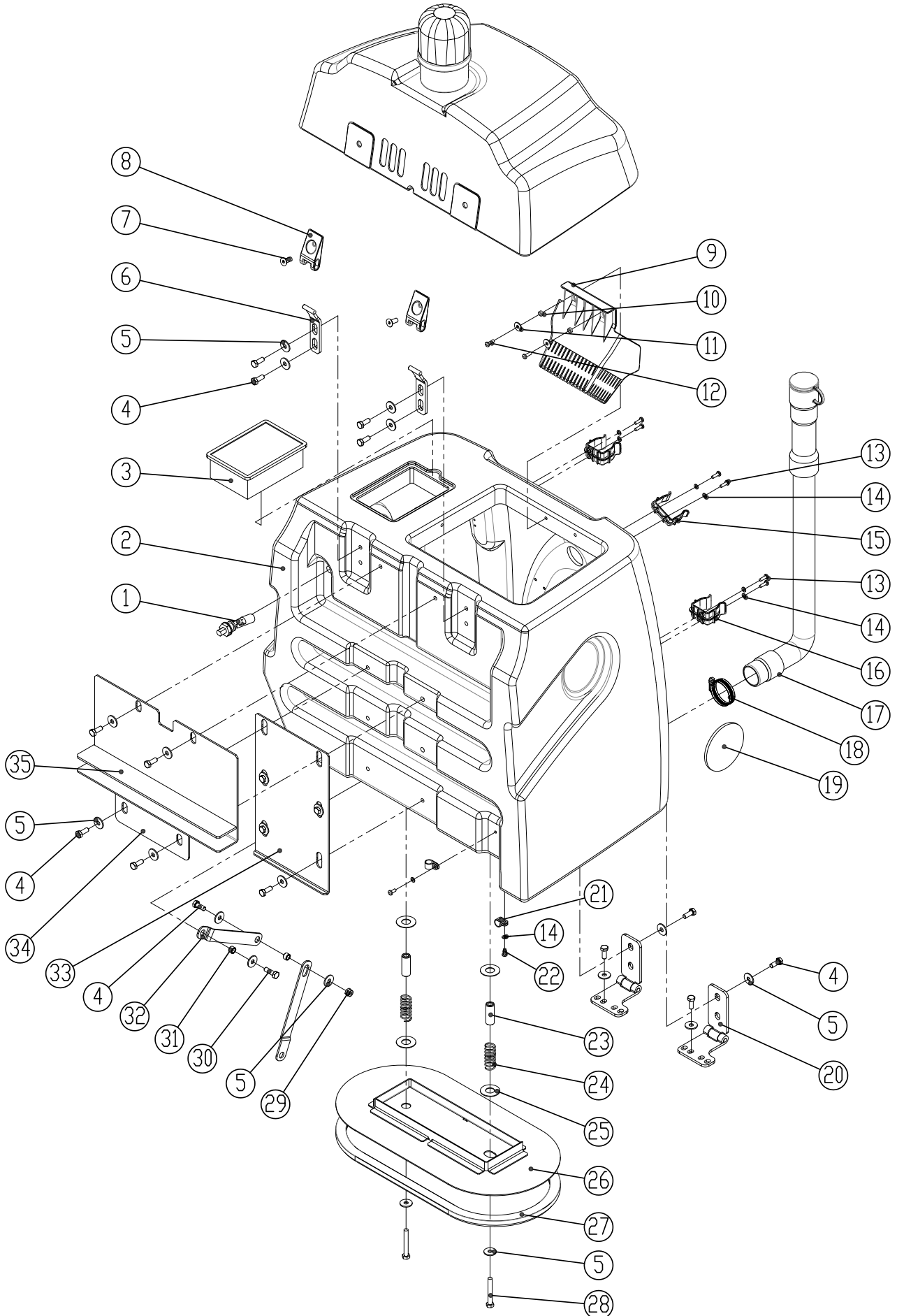

RECOVERY TANK GROUP

DIA NO.	PART NUMBER	DESCRIPTION	NO REQ'D
1	8310238	SENSOR, SOLUTION LEVEL	1
2	8310201	RECOVERY TANK	1
3	8310237	FILTER, DUST	1
4	1021820	BOLT, HEX HEAD, M8×20	21
5	1421824	FLAT WASHER, M8× ϕ 24×2.0	25
6	8310227	HINGE, WELDED	2
7	1513820	SCREW, HEX SOCKET, M8×20	2
8	8310226	HINGE, LEAF	2
9	8310250	DEBRIS COLLECTOR	1
10	8012008	BUSHING	2
11	1421618	FLAT WASHER, M6× ϕ 18×1.6	2
12	1321413	SELF-TAPPING, ST4.8 x 13	2
13	1221516	SCREW, PAN HEAD, M5×16	8
14	1421510	FLAT WASHER, M5× ϕ 10×1.0	12
15	6210111	CLAMP, HOSE	2
16	2310129	CLAMP, HOSE	2
17	8011030	DRAIN HOSE	1
18	1962050	CLAMP, 2 INCH	1
19	4010316	ICE LOGO	2
20	8310126	HINGE ASSY.	2
21	8113009	CLAMP, NYLON	4
22	1221512	SCREW, PAN HEAD, M5×12	4
23	8310221	SPACER	2
24	8310220	COMPRESSION SPRING	2
25	8310222	FLAT WASHER, LARGE	4
26	8310216	COVER, SOLUTION TANK	1
27	8310219	SEALING STRIP	1
28	1022860	BOLT, HEX HEAD, M8×60	2
29	1123810	LOCK NUT, M8	1
30	1021825	BOLT, HEX HEAD, M8×25	1
31	8310225	SLEEVE, ϕ 8.1× ϕ 12.7×7.8	2
32	8310223	ARM, RECOVERY TANK SUPPORT	1
33	8310215	BRACKET, RECOVERY TANK SUPPORT	1
34	8310211	BRACKET, SUPPORT	1
35	8310214	SPACER, RUBBER	1

RECOVERY TANK COVER GROUP

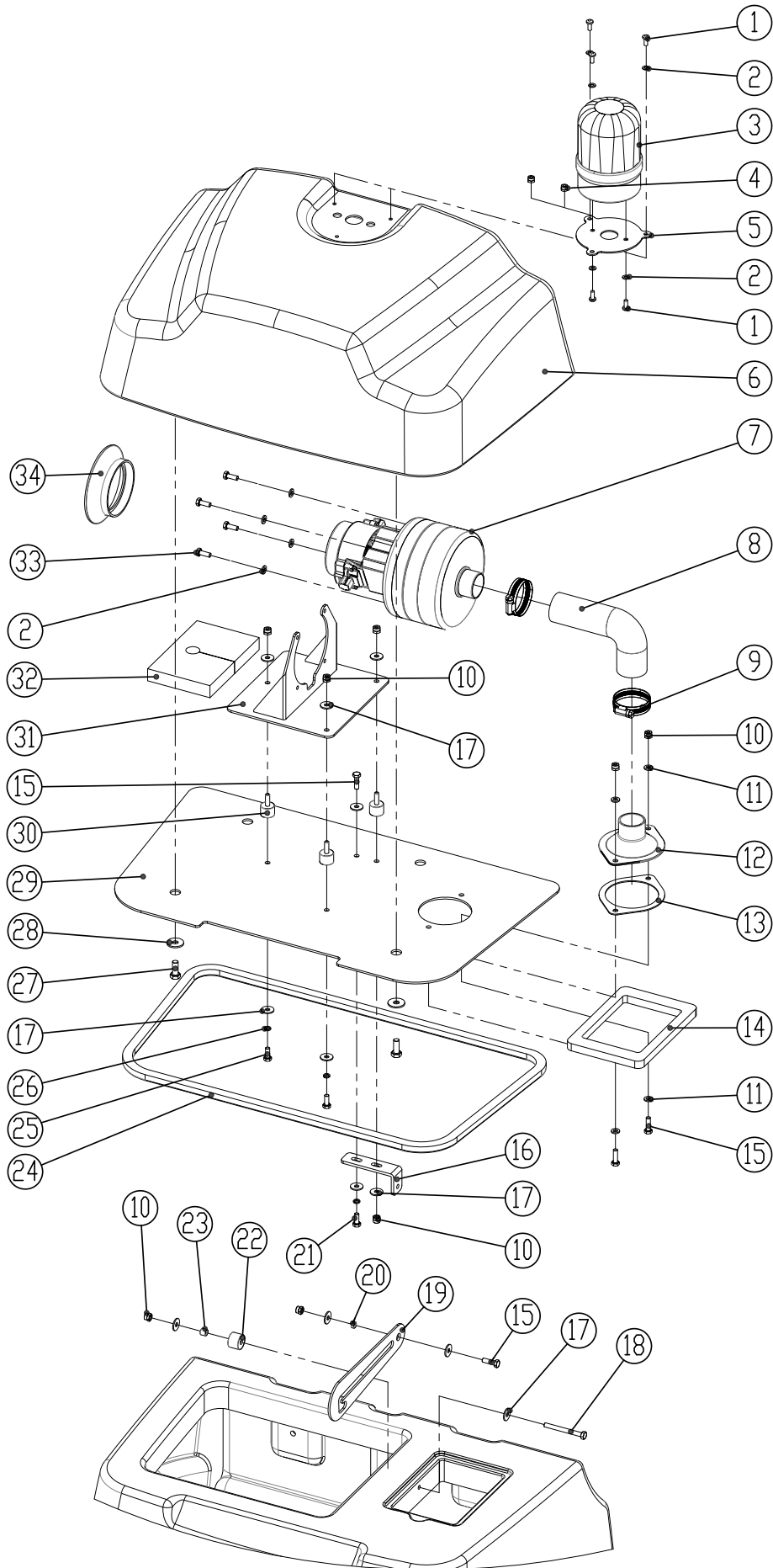

RECOVERY TANK COVER GROUP

DIA NO.	PART NUMBER	DESCRIPTION	NO REQ'D
1	1221512	SCREW, PAN HEAD, M5×12	5
2	1421510	FLAT WASHER, M5× ϕ 10×1.0	9
3	8310138	CAUTION LIGHT	1
4	1123507	LOCK NUT, M5	2
5	8310241	PLATE, CATUION LIGHT	1
6	8310202	RECOVERY TANK COVER	1
7	8310210	VACUUM MOTOR, 3 STAGE	1
8	8310207	VACUUM HOSE	1
9	1962050	CLAMP, 2 INCH	2
10	1123608	LOCK NUT, M6	8
11	1421612	FLAT WASHER, M6× ϕ 12×1.6	4
12	8310204	ADAPTER, VACUUM HOSE	1
13	8310205	GASKET, ADAPTER	1
14	8310230	GASKET, DUST FILTER	1
15	1021620	BOLT, HEX HEAD, M6×20	4
16	8310232	BRACKET	1
17	1421618	FLAT WASHER, M6× ϕ 18×1.6	12
18	1022600	BOLT, HEX HEAD, M6×100	1
19	8310228	SUPPORT, RECOVERY TANK COVER	1
20	8310231	SLEEVE, ϕ 6.4× ϕ 9.5×4	1
21	1021616	BOLT, HEX HEAD, M6×16	1
22	8310236	SPACER, NYLON	1
23	8310235	SLEEVE, ϕ 6.4× ϕ 9.5×8	1
24	8310229	SEALING STRIP	1
25	1021610	BOLT, HEX HEAD, M6×10	2
26	1422616	LOCK WASHER, M6	3
27	1021820	BOLT, HEX HEAD, M8×20	4
28	1421824	FLAT WASHER, M8× ϕ 24×2.0	4
29	8310203	PLATE, VACCUM MOTOR MNTG	1
30	8310208	ISOLATER, M6	3
31	8310209	BRACKET, VACCUM MOTOR	1
32	8310234	INSULATION	1
33	1311316	SCREW, SELF-TAPPING, ST4.8×16	4
34	8310206	SEAL, FAN	1

CONTROL PANNEL GROUP

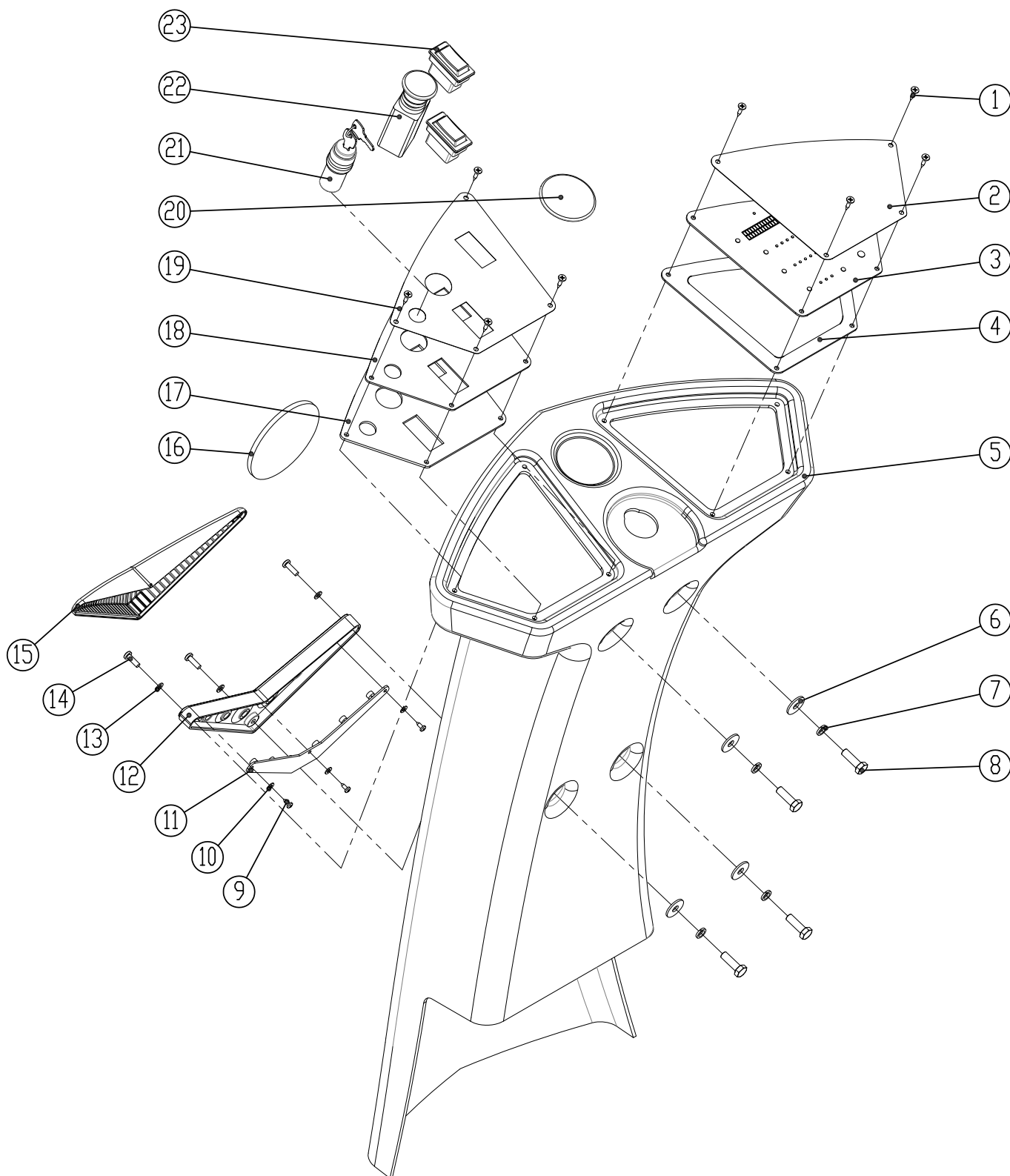

CONTROL PANNEL GROUP

DIA NO.	PART NUMBER	DESCRIPTION	NO REQ'D
1	1321413	SCREW, SELF-TAPPING, ST4.8×13	8
2	8310705	DECAL, CONTROL PANNEL	1
3	8310703	PCB, CONTROL PANNEL	1
4	8310712	GASKET, CONTROL PANNEL	1
5	8310701	CONROL HOUSING	1
6	1421824	FLAT WASHER, M8× ϕ 24×2.0	4
7	1422821	LOCK WASHER, M8	4
8	1021825	BOLT, HEX HEAD, M8×25	4
9	1321110	SCREW, SELF-TAPPING, ST3.5×10	3
10	1421409	FLAT WASHER, M4× ϕ 9×0.8	3
11	8133603	LED LIGHT	1
12	8133601	BASE, LED LIGHT	1
13	1421510	FLAT WASHER, M5× ϕ 10×1.0	3
14	1221520	SCREW, PAN HEAD, M5×20	3
15	8133602	COVER, LED LIGHT	1
16	4010316	ICE LOGO	1
17	8310711	GASKET, SWITCH PANNEL	1
18	8310702	PLATE, SWITCH PANNEL	1
19	8310704	DECAL, SWITCH PANNEL, RS32	1
	8310750	DECAL, SWITCH PANNEL, RS26	1
20	2010121	ICE LOGO, SMALL	1
21	8310706	MAIN KEY SWITCH	1
22	8310707	EMERGENCY STOP SWITCH	1
23	8310709	ROCKER SWITCH	2

MAIN CONTROLLER GROUP

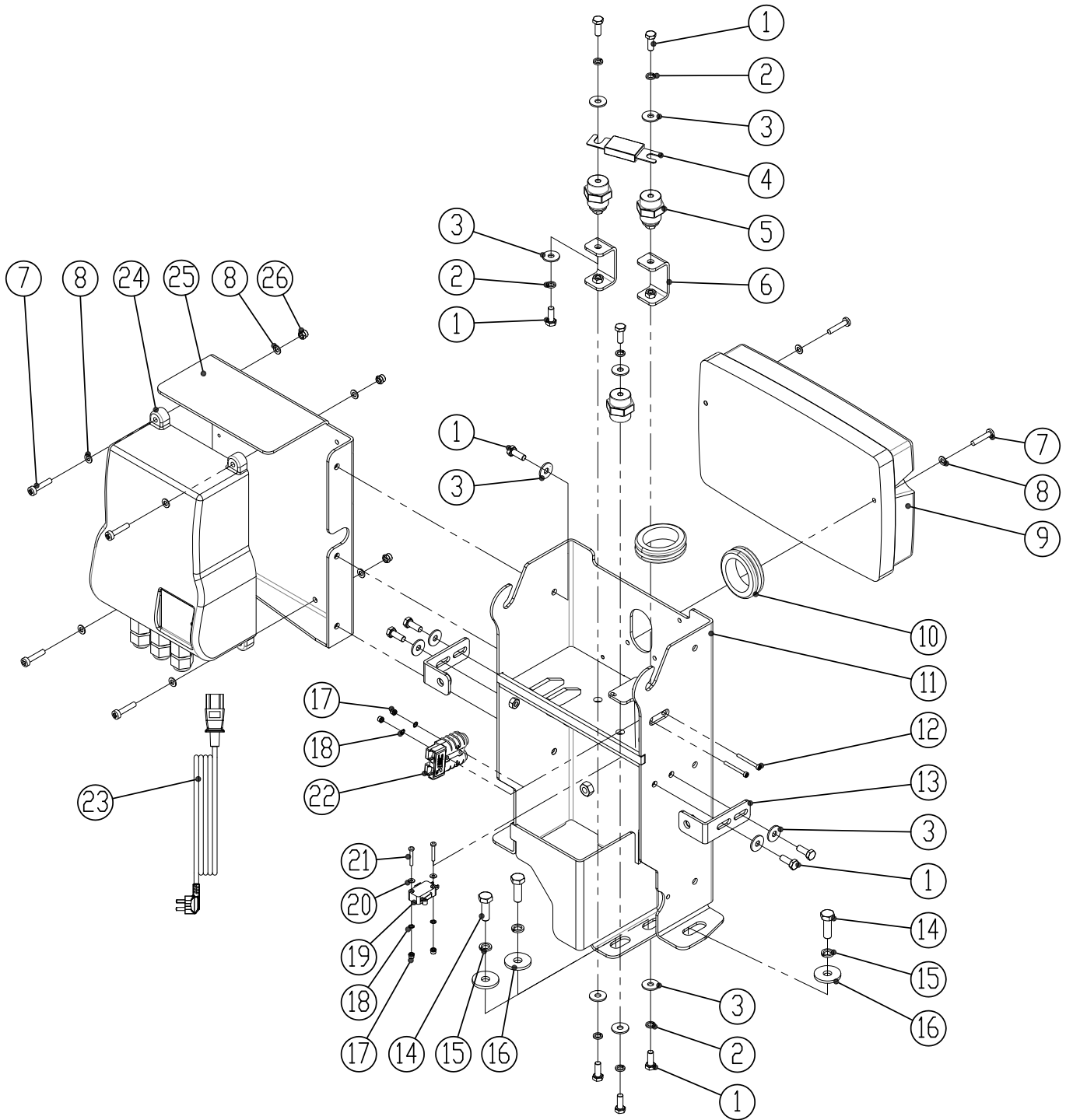

MAIN CONTROLLER GROUP

DIA NO.	PART NUMBER	DESCRIPTION	NO REQ'D
1	1021616	SCREW, HEX HEAD, M6×16	12
2	1422616	LOCK WASHER, M6	8
3	1421618	FLAT WASHER, M6× ϕ 18×1.6	15
4	8310480	FUSE, 150A	1
5	8114705	INSULATOR	3
6	8310422	BRACKET, INSULATOR	2
7	1221525	SCREW, PAN HEAD, M5×25	6
8	1421510	FLAT WASHER, M5× ϕ 10×1.0	10
9	8310470	MAIN CONTROLLER	1
10	8310133	RUBBER GROMMET	2
11	8310420	BRACKET, SCRUB HEAD LIFTING	1
12	1211330	SCREW, PAN HEAD, M3×30	2
13	8310425	BRACKET	2
14	1021825	BOLT, HEX HEAD, M8×25	5
15	1422821	LOCK WASHER, M8	5
16	1421828	FLAT WASHER, M8× ϕ 28×2.5	5
17	1123305	LOCK NUT, M3	4
18	1434300	WASHER, TOOTH, M3	4
19	8310423	MICRO SWITCH	1
20	1421307	FLAT WASHER, M3× ϕ 7×0.5	2
21	1211320	SCREW, PAN HEAD, M3×20	2
22	8113020	CONNECTOR	1
23	8112030	POWER CORD, BATTERY CHARGER, US	1
	8112040	POWER CORD, BATTERY CHARGER, EU	1
	8112050	POWER CORD, BATTERY CHARGER, JP	1
	8112060	POWER CORD, BATTERY CHARGER, CH	1
	8112070	POWER CORD, BATTERY CHARGER, UK	1
24	8210106	ON BOARD BATTERY CHARGER, 25A	1
25	8310428	BRACKET, BATTERY CHARGER	1
26	1123507	LOCK NUT, M5	4

SEAT & DETERGENT SYSTEM GROUP

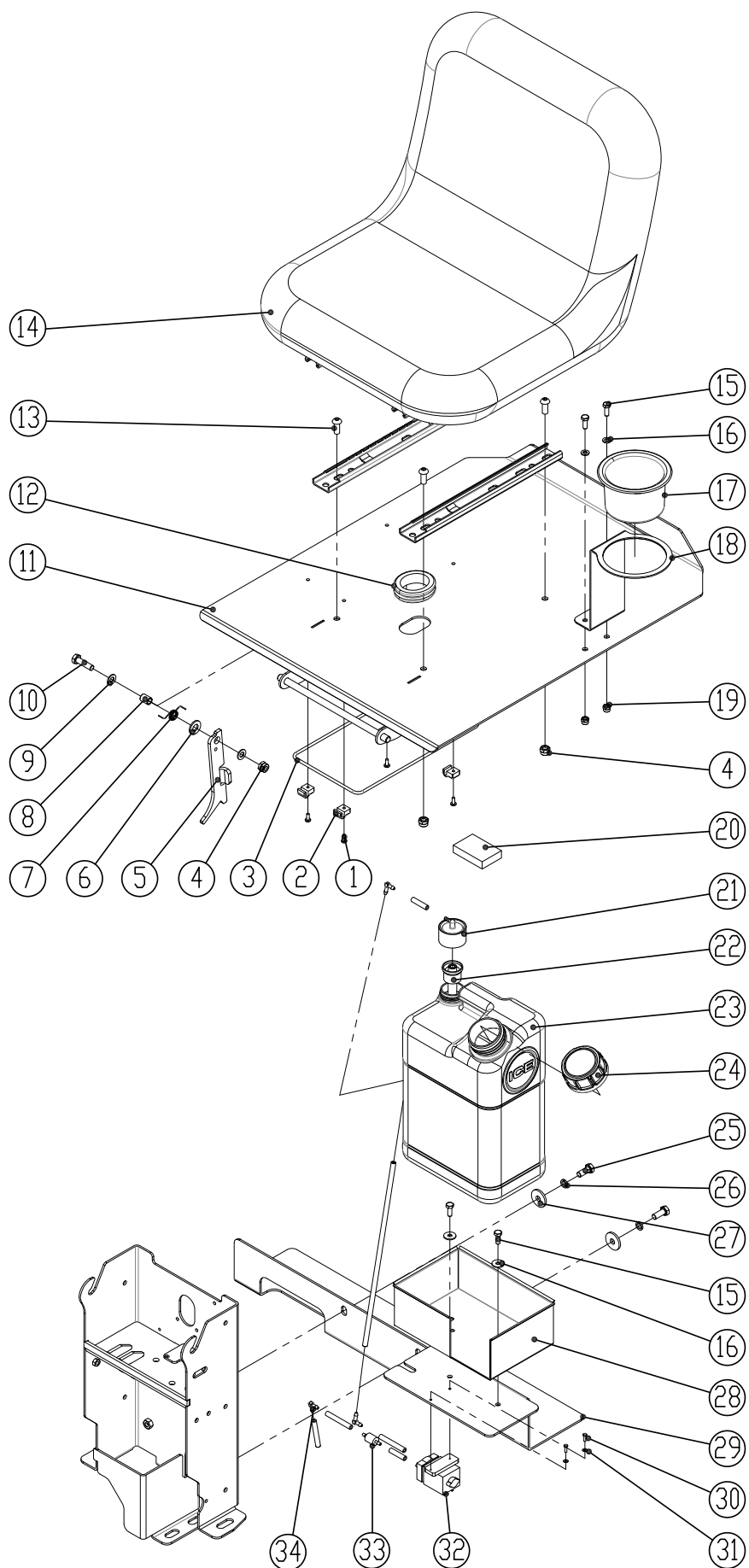

SEAT & DETERGENT SYSTEM GROUP

DIA NO.	PART NUMBER	DESCRIPTION	NO REQ'D
1	1221412	SCREW, HEX HEAD, M4×12	4
2	8133502	CLAMP	4
3	8133501	CARGO NET	1
4	1123810	LOCK NUT, M8	5
5	8310413	SUPPORT, SEAT	1
6	8117007	NYLON SPACER	1
7	8310415	TORSION SPRING	1
8	8310414	SLEEVE, $\phi 8.2 \times \phi 11 \times 15$	1
9	1421816	FLAT WASHER, M8× $\phi 16 \times 1.6$	2
10	1021830	BOLT, HEX HEAD, M8×30	1
11	8310411	PLATE, SEAT MNTG	1
12	8310133	RUBBER GROMMET	1
13	1512820	SCREW, HEX SOCKET, M8×20	4
14	8310402	SEAT	1
15	1021616	SCREW, HEX HEAD, M6×16	4
16	1421618	FLAT WASHER, M6× $\phi 18 \times 1.6$	4
17	8310418	CUP HOLDER	1
18	8310419	BRACKET, CUP HOLDER	1
19	1123608	LOCK NUT, M6	2
20	8310460	SPACER	1
21	8310463	ADAPTOR, KEY	1
22	8310464	INSERT, LOCK	1
23	8310461	BOTTLE, DETERGENT	1
24	8310462	CAP, BOTTLE	1
25	1021820	BOLT, HEX HEAD, M8×20	2
26	1422821	LOCK WASHER, M8	2
27	1421828	FLAT WASHER, M8× $\phi 28 \times 2.5$	5
28	8310465	BOX, DETERGENT BOTTLE	1
29	8310421	BRACKET	1
30	1221312	SCREW, HEX HEAD, M3×12	2
31	1421307	FLAT WASHER, M3× $\phi 7 \times 0.5$	2
32	8310372	PUMP	1
33	8310466	ONE WAY VALVE	1
34	8310467	FITTING	5

BATTERY GROUP

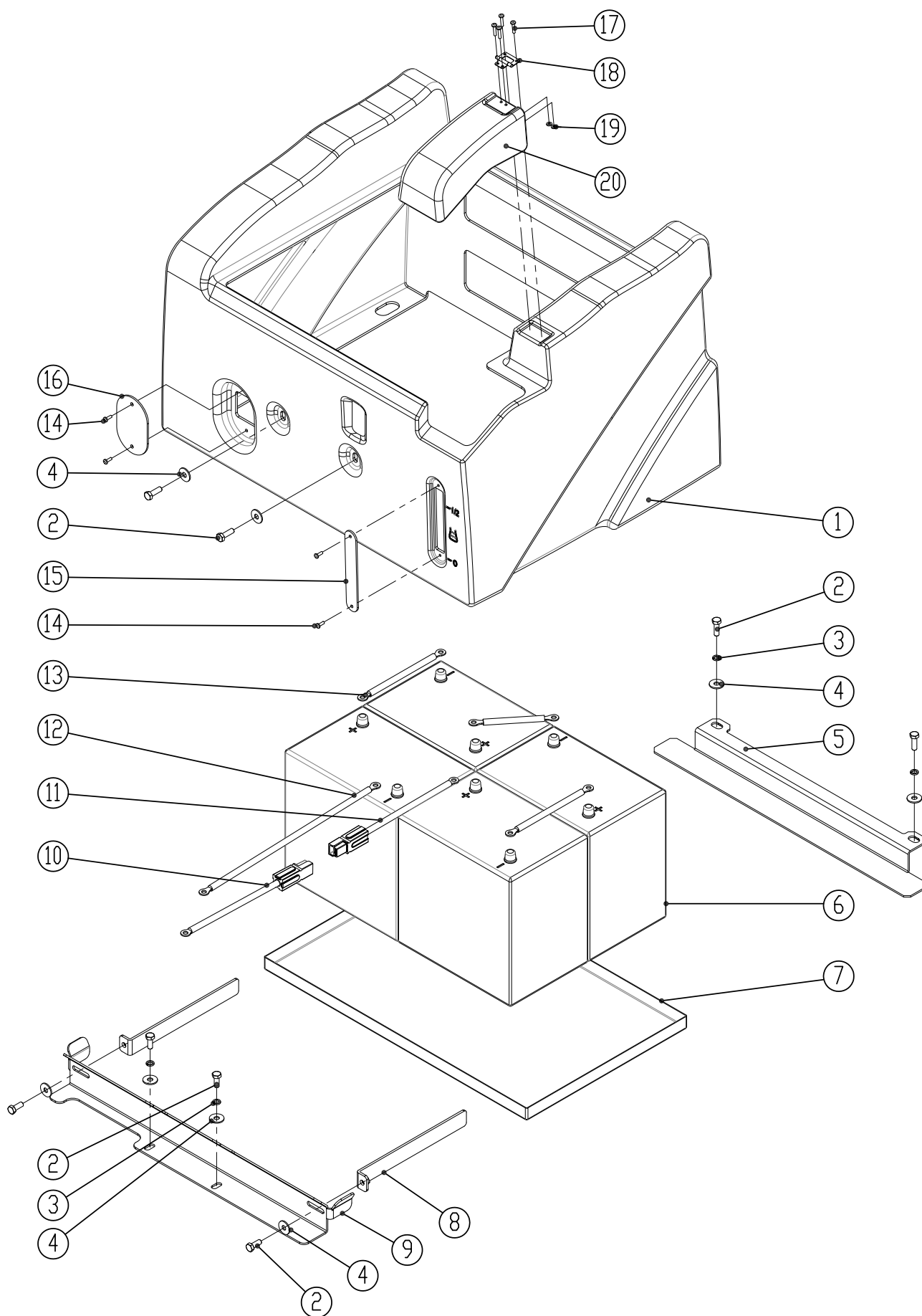

BATTERY GROUP

DIA NO.	PART NUMBER	DESCRIPTION	NO REQ'D
1	8310401	BOX, BATTERY	1
2	1021820	BOLT, HEX HEAD, M8×20	8
3	1422821	LOCK WASHER, M8	4
4	1421824	FLAT WASHER, M8× ϕ 24×2.0	8
5	8310131	SUPPORT, BATTERY, REAR	1
6	8210105	BATTERY, 6V 230AH	4
7	8310135	TRAY, BATTERY	1
8	8310407	PLATE	2
9	8310136	SUPPORT, BATTERY, FRONT	1
10	8310736	BATTERY CONNECT CABLE, RED	1
11	8310737	BATTERY CONNECT CABLE, RED	1
12	8310733	BATTERY CONNECT CABLE, BLACK	1
13	8210141	BATTERY CONNECT CABLE, BLACK	3
14	1221412	SCREW, PAN HEAD, M4×12	4
15	8310406	COVER	1
16	8210114	COVER	1
17	1662316	RIVET, 3.2×16	4
18	8310404	HINGE ASSEMBLY	1
19	1421409	FLAT WASHER, M4× ϕ 9×0.8	4
20	8310403	COVER	1

SCRUB HEAD LIFTING GROUP

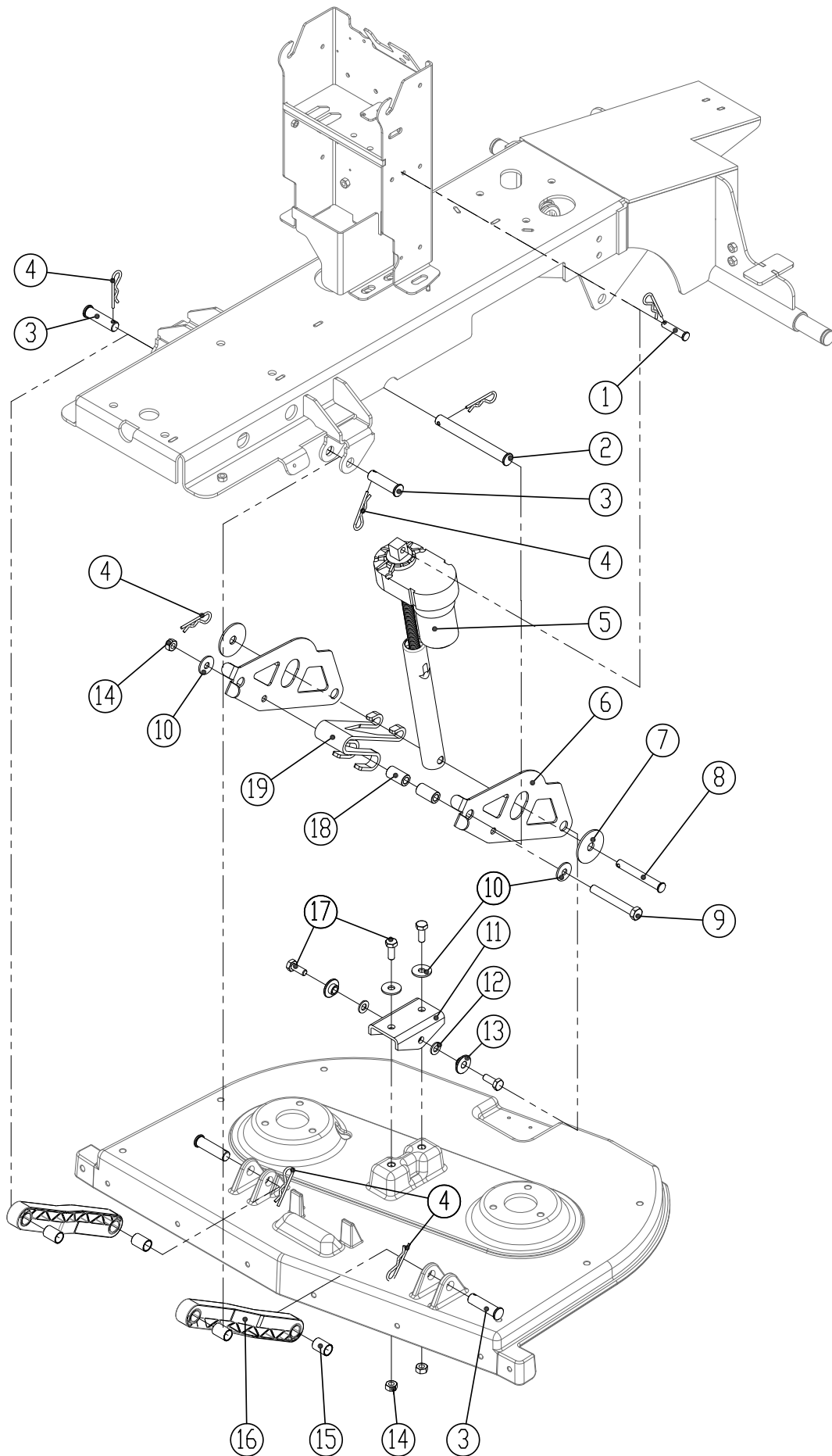

SCRUB HEAD LIFTING GROUP

DIA NO.	PART NUMBER	DESCRIPTION	NO REQ'D
1	8210301	PIN, ϕ 9.5×38	1
2	8310311	PIN, ϕ 16×150	1
3	8310312	PIN, ϕ 16×57	4
4	8210309	PIN, COTTER	7
5	8310303	LINEAR ACTUATOR	1
6	8310305	PLATE, ARM, SCRUB HEAD LIFTING	2
7	8310314	FLAT WASHER, LARGE	2
8	8310313	PIN, ϕ 12×90	1
9	1032090	BOLT, HEX HEAD, M10×90	1
10	1421030	FLAT WASHER, M10× ϕ 30×2.5	4
11	8310304	BRACKET, SCRUB HEAD LIFTING	1
12	1421020	FLAT WASHER, M10× ϕ 20×2	2
13	8310307	BUSHING, FLANGE	2
14	1123012	LOCK NUT, M10	3
15	8310144	SLEEVE, ϕ 16× ϕ 18.6×25.4	4
16	8310118	ARM, SCRUB HEAD LIFTING	2
17	1011025	BOLT, HEX HEAD, M10×25	4
18	8310306	SLEEVE, ϕ 10.5× ϕ 18.5×34	2
19	8310308	SPRING	1

SCRUB HEAD GROUP

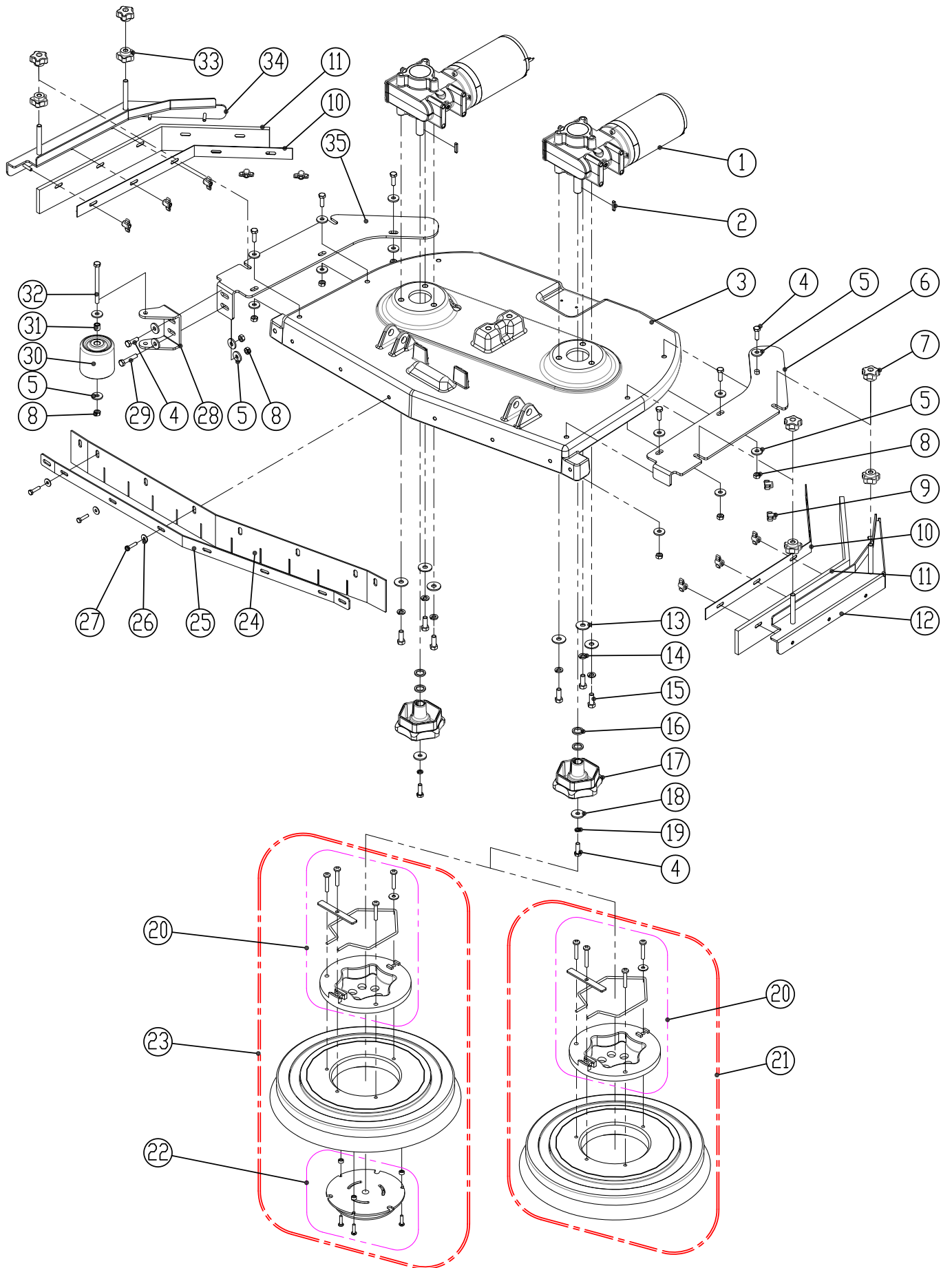

SCRUB HEAD GROUP

DIA NO.	PART NUMBER	DESCRIPTION	NO REQ'D
1	8310302	BRUSH MOTOR, 24VDC 450W	2
2	1655025	KEY, 5×5×25	2
3	8311301	SCRUB HEAD HOUSING, RS26	1
	8310301	SCRUB HEAD HOUSING, RS32	1
4	1021830	BOLT, HEX HEAD, M8×30	9
5	1421824	FLAT WASHER, M8× ϕ 24×2.0	18
6	8310356	BRACKET, LEFT	1
7	8210532	KNOB, M10	4
8	1123810	LOCK NUT, M8	9
9	8210531	KNOB, M6	10
10	8310355	CLAMP, SIDE SKIRT	2
11	8310352	BLADE, SIDE SKIRT	2
12	8310357	BRACKET, SIDE SKIRT, LEFT	1
13	1421020	FLAT WASHER, M10× ϕ 20×2.0	6
14	1422010	LOCK NUT, 3/8	6
15	1023010	BOLT, HEX HEAD, 3/8-16×1	6
16	8210804	SPACER	4
17	8210805	HUB, BRUSH DRIVE	2
18	1421828	FLAT WASHER, M8× ϕ 28×3.0	2
19	1422821	LOCK WASHER, M8	2
20	9000004	CLUTCH, G-400S	2
21	9050013	BRUSH, 13 INCH, RS26	2
	9050016	BRUSH, 16 INCH, RS32	2
22	9000003	CENTER LOCK, #3	2
23	9040013	PAD DRIVER, 13 INCH, RS26	2
	9040016	PAD DRIVER, 16 INCH, RS32	2
24	8311358	SKIRT, RS26	1
	8310358	SKIRT, RS32	1
25	8311359	CLAMP, SKIRT, RS26	1
	8310359	CLAMP, SKIRT, RS32	1
26	1421618	FLAT WASHER, M6× ϕ 18×1.6	7
27	1021616	BOLT, HEX HEAD, M6×16	7
28	8310361	BRACKET, PROTECTIVE WHEEL	1
29	1021840	BOLT, HEX HEAD, M8×40	1
30	8310362	PROTECTIVE WHEEL	1
31	8115404	SLEEVE, ϕ 8× ϕ 12.7×12.7	6
32	1022800	BOLT, HEX HEAD, M8×100	1
33	8310354	KNOB, M10	4
34	8310351	BRACKET, SIDE SKIRT, RIGHT	1
35	8310353	BRACKET, RIGHT	1

SQUEEGEE GROUP

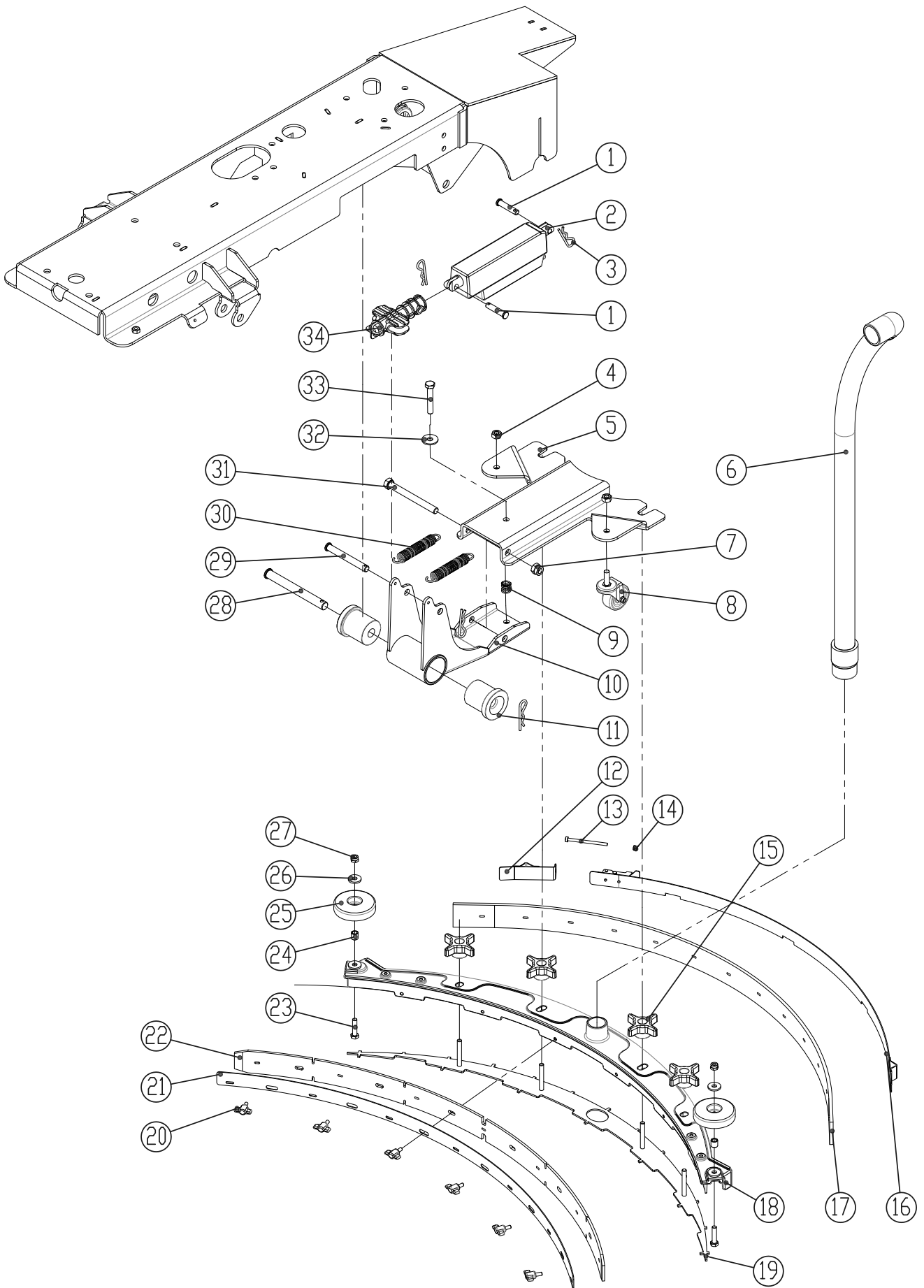

SQUEEGEE GROUP

DIA NO.	PART NUMBER	DESCRIPTION	NO REQ'D
1	8310506	PIN, $\phi 10 \times 45$	2
2	8310502	LINEAR, ACTUATOR	1
3	8210309	PIN, COTTER	4
4	1121008	HEX NUT, M10	2
5	8310503	BRACKET, SQUEEGEE	1
6	8310240	VACUUM HOSE	1
7	1123115	LOCK NUT, M12	1
8	8310550	CASTER, 2 INCH	2
9	8310501	COMPRESSION SPRING,	1
10	8310504	ARM, SQGE LIFTING	1
11	8310505	FLEX BUSHING, TPU	2
12	8210525	SHORT CLAMP ASSEMBLY	1
13	1221575	SCREW, PAN HEAD, M5 \times 75	1
14	1123507	LOCK NUT, M5	1
15	8210518	KNOB, M8	4
16	8311514	CLAMP ASSEMBLY, RS26	1
	8310514	CLAMP ASSEMBLY, RS32	1
17	8311531	REAR BLADE, LINATEX, RS26	1
	8310531	REAR BLADE, LINATEX, RS32	1
18	8311511	SQUEEGEE HOSING, RS26	1
	8310511	SQUEEGEE HOSING, RS32	1
19	8311512	RETAINER, SQUEEGEE, RS26	1
	8310512	RETAINER, SQUEEGEE, RS32	1
20	8210531	KNOB, M6	6
21	8311513	FRONT CLAMP, RS26	1
	8310513	FRONT CLAMP, RS32	1
22	8311532	FRONT BLADE, LINATEX, RS26	1
	8310532	FRONT BLADE, LINATEX, RS32	1
23	1021835	BOLT, HEX HEAD, M8 \times 35	2
24	8115404	SLEEVE, $\phi 8 \times \phi 12.7 \times 12.7$	2
25	8116009	PROTECTIVE WHEEL	2
26	1421824	FLAT WASHER, M8 $\times \phi 24 \times 2$	4
27	1123810	LOCK NUT, M8	2
28	8310311	PIN, $\phi 16 \times 150$	1
29	8310508	PIN, $\phi 12 \times 100$	1
30	8310509	EXTENSION SPRING	2
31	1031212	BOLT, HEX HEAD, M12 \times 120	1
32	1421030	FLAT WASHER, M10 $\times \phi 30 \times 2.5$	1
33	1021060	BOLT, HEX HEAD, M10 \times 60	1
34	8310507	ADAPTER	1

SOLUTION & DETERGENT SYSTEM

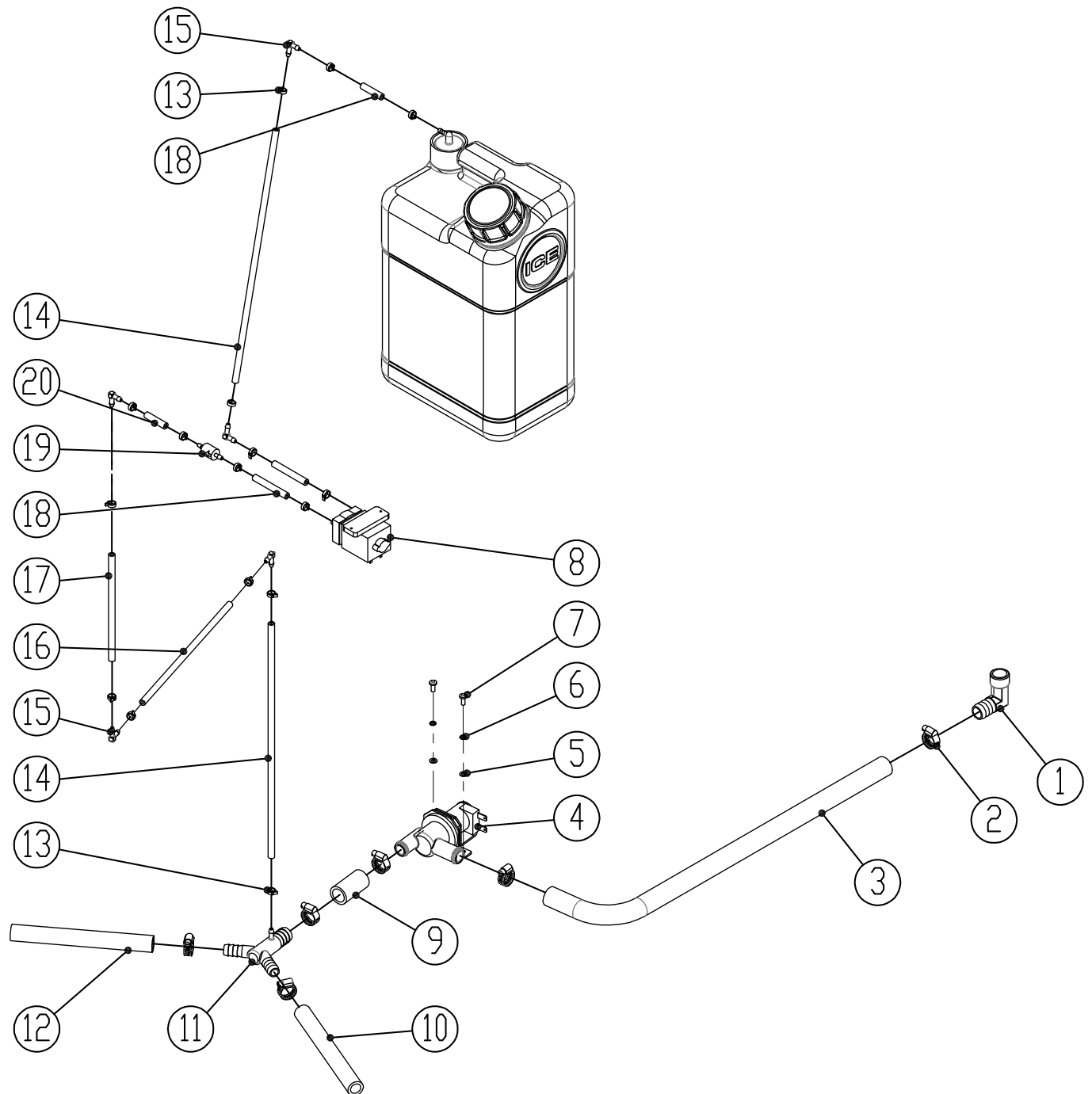

SOLUTION & DETERGENT SYSTEM

DIA NO.	PART NUMBER	DESCRIPTION	NO REQ'D
1	8310124	ELBOW, G1/2	1
2	1962025	CLAMP 16-25MM	6
3	8310901	TUBING, ID=16MM L=500MM	1
4	8310371	SOLENOID VALVE, 24VDC	1
5	1421510	FLAT WASHER, M5× ϕ 10×1.0	2
6	1422513	LOCK WASHER M5	2
7	1221512	SCREW, PAN HEAD, M5×12	2
8	8310372	PUMP	1
9	8310902	TUBING, ID=16MM L=40MM	1
10	8310903	TUBING, ID=12MM L=175MM	1
11	8310373	FITTING, PLASTIC	1
12	8310904	TUBING, ID=12MM L=210MM	1
13	1914080	TIE, 3×80MM	16
14	8310905	TUBING, ID=4MM L=310MM	2
15	8310467	FITTING	5
16	8310906	TUBING, ID=4MM L=420MM	1
17	8310907	TUBING, ID=4MM L=140MM	1
18	8310908	TUBING, ID=4MM L=50MM	2
19	8310466	ONE WAY VALVE	1
20	8310909	TUBING, ID=4MM L=30MM	2

WEAR AND TEAR PARTS

WEAR AND TEAR PARTS

DIA NO.	PART NUMBER	DESCRIPTION	NO REQ'D
1	8310119	10" WHEEL, PU TIRE	2
2	8116009	PROTECTIVE WHEEL	2
3	8310362	PROTECTIVE WHEEL	1
4	8311531	REAR BLADE, LINATEX, RS26	1
	8310531	REAR BLADE, LINATEX, RS32	1
5	8311532	FRONT BLADE, LINATEX, RS26	1
	8310532	FRONT BLADE, LINATEX, RS32	1
6	9050013	BRUSH, 13 INCH, RS26	2
	9050016	BRUSH, 16 INCH, RS32	2
7	9040013	PAD DRIVER, 13 INCH, RS26	2
	9040016	PAD DRIVER, 16 INCH, RS32	2

SCRUBBER MAIN CONTROLLER

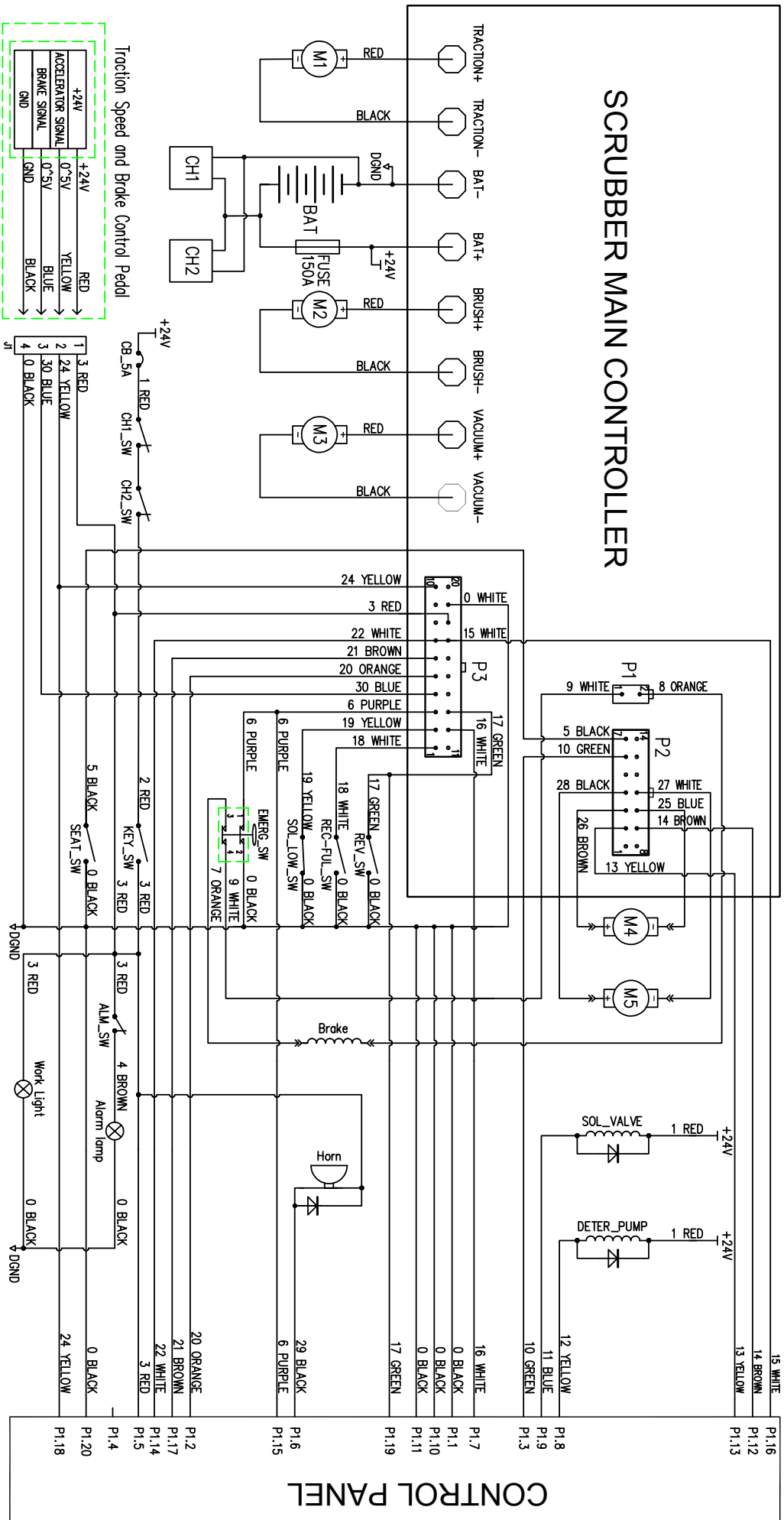

- M1: Traction motor
- BAT: 4-6V Batteries
- CH1: Off-board battery charger port
- CH2: On-board battery charger
- M2: Brush motors
- M3: Vacuum motor
- CH1_SW: Off-board charger interlock switch
- CH2_SW: On-board charger interlock switch

- M4: Scrub head lifting actuator
- M5: Squeegee lifting actuator
- SOL_VALVE: Solution flow solenoid valve
- DETER_PUMP: Detergent flow pump
- REV_SW: Reverse switch
- REC_FUL_SW: Recovery tank water level switch
- SOL_LOW_SW: Solution tank water level switch
- EMERG_SW: Emergency stop switch

- Brake: Brake coil
- Horn: Horn
- KEY_SW: Main power key switch
- SEAT_SW: Seat switch
- ALM_SW: Alarm lamp switch
- Alarm lamp: Alarm lamp
- Work light: work LED light