

# tielbürger®

- Ⓛ Ersatzteilliste
- Ⓛ Pièces détachées
- Ⓛ Spare parts list
- Ⓛ Lista ricambi
- Ⓛ Deleliste

**tk 48**





## Inhaltsverzeichnis

Achse .....	2
Arbre	
Axle	
Asse	
Aksel	
Motor B&S .....	4
Moteur	
Motor	
Motore	
Motor	
Motor Honda GCV 160 .....	6
Moteur	
Motor	
Motore	
Motor	
Keilriemenscheibe .....	8
Poulie	
Vbelt pulley	
Puleggia	
Kileremskive	
Getriebe .....	10
Boîte de vitesses	
Gear drive	
Trasmissione	
Gear	
Stützrad .....	12
Rouesupport	
Supporting wheel	
Ruota supporto	
Hjul	
Variator .....	14
Kehrwalzenantrieb .....	16
Entraînement de la brosse	
Brush drive	
Trazione spazzole	
Feievalsdrift	
Lenker .....	18
Mancheron	
Handle bars	
Manubrio	
Styre	
Elektrostarter .....	20
Starter électrique	
Electric starter	
Avv. elettrico	
Wassersprüheinrichtung (Zubehör) .....	22
Equipement d'arrosage (Accessoires)	
Water spraying device (Appurtenances)	
Impianto spruzzo (Gli accessori)	
Motor Honda GXV 140 .....	24
Moteur	
Motor	
Motore	
Motor	

### WICHTIG!

Die Spalte „Bemerkung“ hilft Ihnen, Teile zu identifizieren.

Verwenden Sie ausschließlich Originalersatzteile vom Hersteller. Dadurch wird die sichere Funktion des Gerätes gewährleistet.

Positionsnummern in Klammern sind Verschleißteile.

### IMPORTANT!

Under „remarks“ you will be able to identify the parts. Please use only genuine spare parts of the manufacturer. Only this way, a safe operation of the machine is guaranteed.

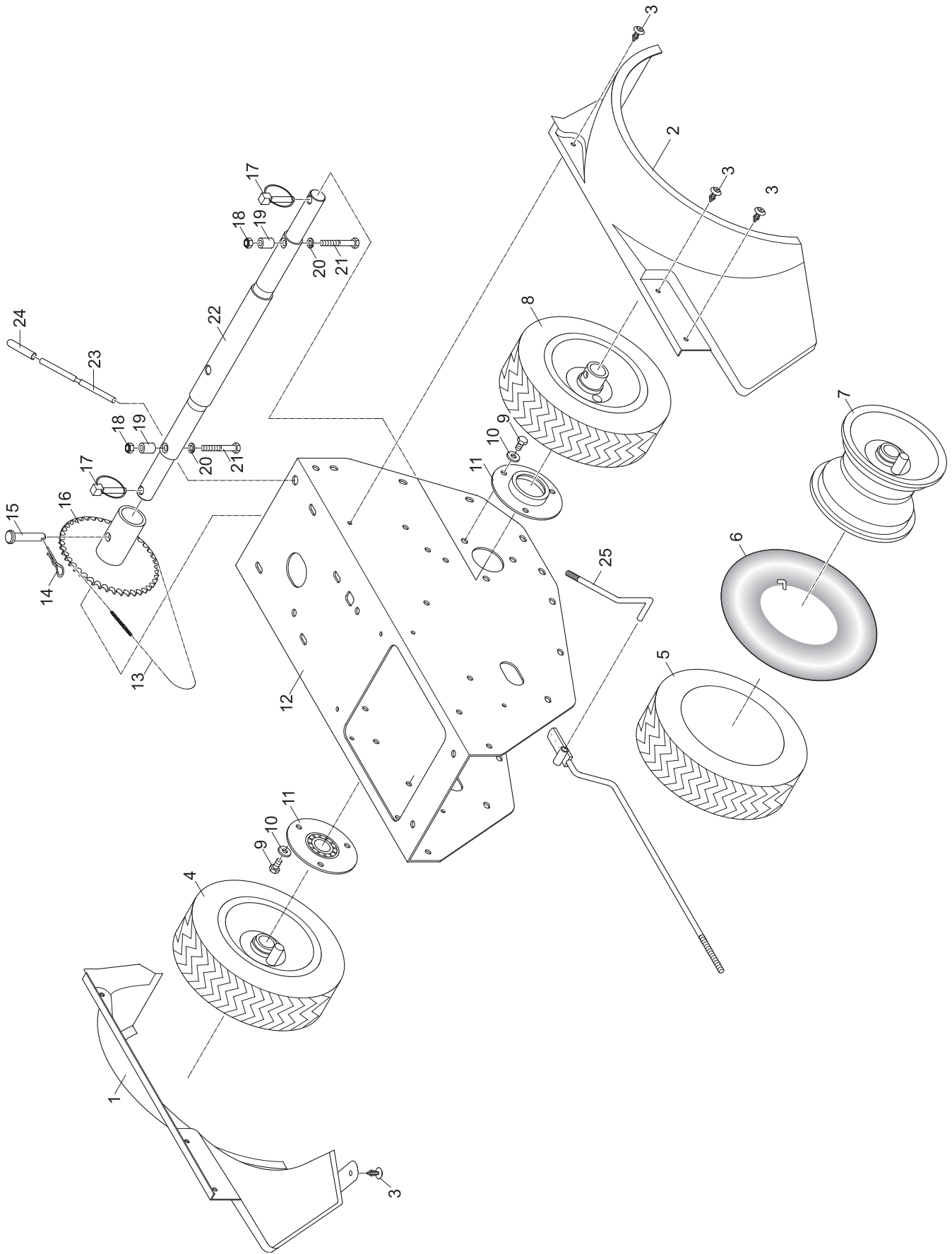

Pos.-Nr. Rep.	Bestellnummer Réfarence	Anzahl Qté.	Bezeichnung	Désignation	Description	Descrizione	Benevnelse	Bemerkung Remarks Osservazione Bemerkninger
Pos.	Article number	Quant.						
Pos.	Nr. codice	Q.tà						
Bilde-Nr.	Bestillings-Nr	Antall						
1	HJ-010-187	1	Kotflügel, rechts	Aile, droite	Mudguard, right	Parafango, dx		
2	HJ-010-186	1	Kotflügel, links	Aile, gauche	Mudguard, left	Parafango, sx		
(3)	HJ-010-182	8	Schraubniet	Rivet	Rivet	Ribattino	Nagle	
4	AD-370-050 TS	1	Rad, rechts	Roue droite	Wheel right	Ruota dx	Hjul høyre	für 13x5,00 - 6
(5)	HN-022-013	2	Decke	Enveloppe	Cover	Coperchio	Dekk	13 x 5,00 - 6
6	HN-032-010	2	Schlauch	Outre	Tube	Camera aria	Slange	4,50 - 6
7	AZ-009-017p9010	2	Felge	Jante	Rim/Hub	Cerchio	Felg	
8	AD-370-051 TS	1	Rad, links	Roue gauche	Wheel left	Ruota sx	Hjul venstre	
9	HO-020-082z	6	Sechskantschraube	Vis à six pans	Hexagon bolt	Vite esagonale	Sekskantskrue	M 8 x 16
10	HW-050-007z	14	Scheibe	Rondelle	Washer	Rondella	Skive	A 8,4
(11)	AA-120-100-9005	1	Flansch	Flasque	Flange	Flangia	Flens	
12	AD-350-146-3000	1	Gehäuse	Arbre	Housing	Scatola	Hus	
(13)	HD-030-006	1	Rollenkette m. Schloß	Chaîne à rouleaux	Roller chain	Catena a rullimi	Kjede	1 / 2 x 5 / 16"
(14)	KG-011-001z	1	Federstecker	Support de fiche	Hairpin clip	Spina elastica	Låsesplint	Ø 2,5 einfach
15	KC-001-033z	1	Splintbolzen	Boulon	Clevis pin	Bullone copiglia	Splintbolt	
16	AA-120-146g	1	Kettenrad	Roue de chaîne	Sprocket	Ruota dentata	Kjedehjul	
17	AZ-008-004	2	Klappsplint	Goupille	Hinged pin	Spina sicurezza	Orepinne	Ø 9 verz.
18	HR-030-005z	2	Sicherungsmutter	écrou de sûreté	Locknut	Dado autobloccante	Låsemutter	M 8
19	DC-131-018z	2	Hülse	Douille	Spacer tube	Boccola	Hylse	
20	HT-010-008z	2	Federring	Bague de ressort	Spring washer	Anello elastico	Sprengskive	A 8,0
21	HO-010-090z	2	Sechskantschraube	Vis à six pans	Hexagon bolt	Vite esagonale	Sekskantskrue	M 8 x 55
22	DC-281-058z	1	Achse	Arbre	Axle	Asse	Aksel	
23	DJ-010-007z	1	Verlängerung	Rallonge	Extension	Prolunga	Forlenger	125 x 10 x 1,6
(24)	HJ-010-010	1	PVC- Handgriff	Poignée	PVC grip	Manopola PVC	Handtak	Ø 9; 55 lang
25	DC-060-067z	1	Schalthebel	Levier d'embrayage	Shifting lever	Leva comando	Gristang	144 x 44 x 8



Lesen Sie bitte die Bedienungsanleitung und Sicherheitsanweisungen  
für diesen und jeden weiteren Bohrer sorgfältig durch.  
Bitte lesen Sie die Bedienungsanleitung und die  
Sicherheitsanweisungen sorgfältig durch, bevor Sie  
den Bohrer in Betrieb nehmen.  
Bitte lesen Sie die Bedienungsanleitung und die  
Sicherheitsanweisungen sorgfältig durch, bevor Sie  
den Bohrer in Betrieb nehmen.

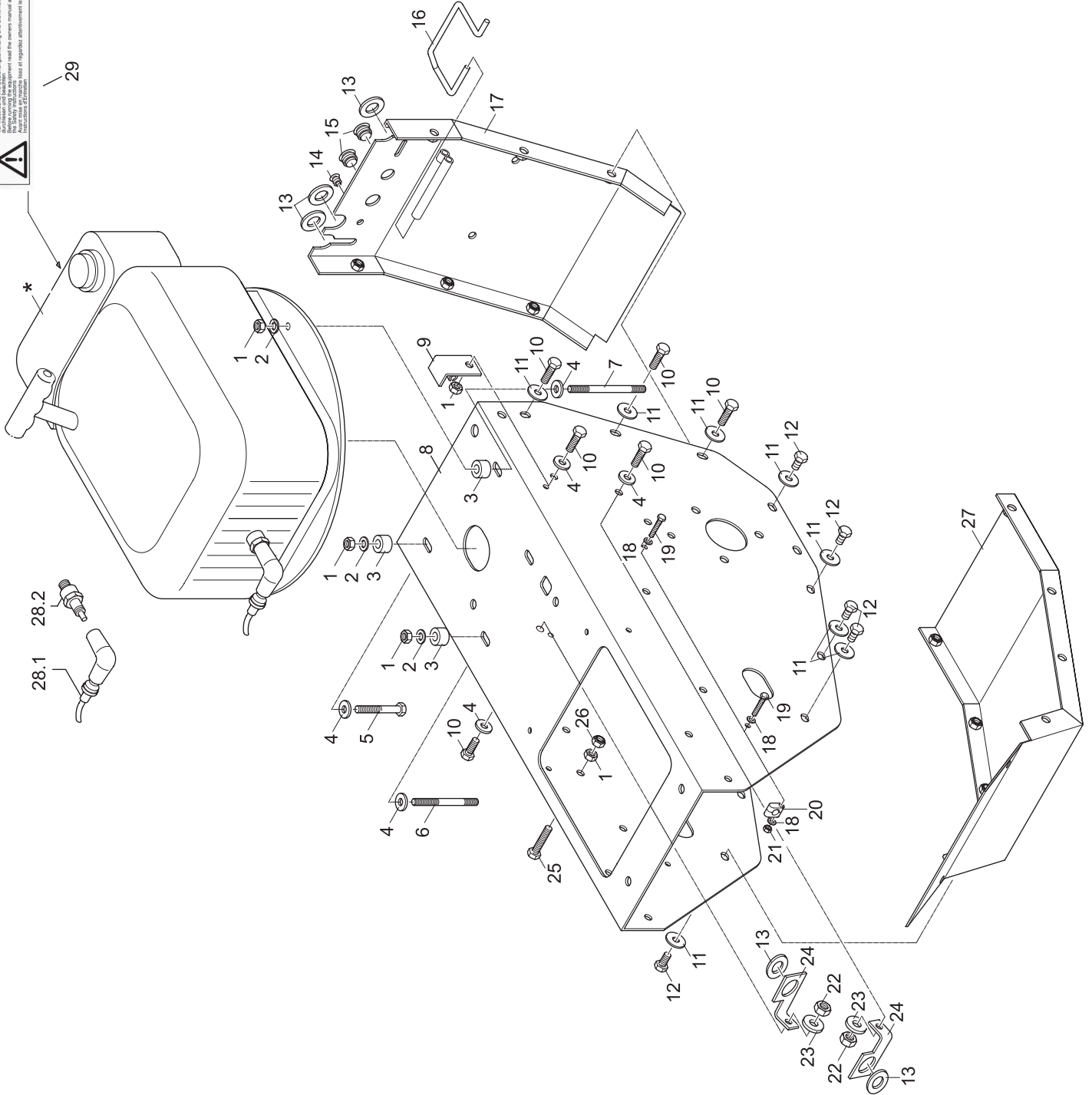

\* Motoren über Fachhandel beziehen  
B & S

Pos.-Nr.	Bestellnummer	Anzahl	Désignation	Description	Descrizione	Benevnelse	Bemerkung
Rep.	Référence	Qté.					Remark
Pos.	Article number	Quant.					Remarks
Pos.	Nr. codice	Q.tà					Osservazione
Bilde-Nr.	Bestillings-Nr	Antall					Bemerkninger
1	HR-010-005z	9	écrou à six pans	Hexagon nut	Dado esagonale	Sekskantmutter	M 8
2	HW-010-007z	3	Rondelle	Washer	Rondella	Skive	B 8,4
3	DC-181-041z	3	Douille	Spacer tube	Boccola	Hylse	
4	HW-050-007z	8	Rondelle	Washer	Rondella	Skive	Ø 8,4
5	HO-010-090z	2	Vis à six pans	Hexagon bolt	Vite esagonale	Sekskantskrue	M 8 x 55
6	DC-081-013z	1	Boulon	Pin	Bullone	Bolt	89
7	DC-081-016z	1	Boulon	Pin	Bullone	Bolt	105
8	AD-350-146-3000	1	Arbre	Housing	Scatola	Hus	
9	AD-350-143g	1	Support	Bracket	Supporto	Støtte	
10	HO-020-083z	11	Vis à six pans	Hexagon bolt	Vite esagonale	Sekskantskrue	M 8 x 20
11	HW-060-007	14	Rondelle	Washer	Rondella	Skive	A 8,4
12	HO-020-082z	8	Vis à six pans	Hexagon bolt	Vite esagonale	Sekskantskrue	M 8 x 16
13	KO-001-023	5	Guide noire	Grommet black	Bussola di passaggio nero	Gjennomføring sort	
14	HJ-010-189	3	Lamellenstopfen, rund	Cap	Tappo		8 – 9mm
15	HJ-010-188	2	Lamellenstopfen, rund	Cap	Tappo		15 – 18,4mm
(16)	HI-040-016z	1	Rastfeder	Positioning spring	Molla arresto	Fjaer	
16a	HU-060-003	1	Scheibe	Washer	Rondella	Skivecheibe	
17	AD-350-142-3000	1	Heckblech	Rear cover	Lamiera posteriore	Bakre deksel	
18	HW-010-002z	4	Scheibe	Washer	Rondella	Skive	A 5,3
19	HO-020-032z	2	Sekskantschraube	Hexagon bolt	Vite esagonale	Sekskantskrue	M 5 x 25
20	KO-001-124	2	Zugentlastungsschelle	Strain relief shackle			7,5 – 8,5
21	HR-030-003z	2	Sicherungsmutter	Locknut	Dado autobloccante	Låsemutter	M 5
22	HR-010-006z	6	Sekskantmutter	Hexagon nut	Dado esagonale	Sekskantmutter	M 10
23	HW-050-009z	5	Scheibe	Washer	Rondella	Skive	Ø 10,5
24	DA-240-420	2	Führungswinkel	Slide	Angolare	Vinkel	
25	HO-020-087z	1	Sekskantschraube	Hexagon bolt	Vite esagonale	Sekskantskrue	M 8 x 40
26	HR-030-005z	1	Sicherungsmutter	Locknut	Dado autobloccante	Låsemutter	M 8
27	AD-350-141-3000	1	Bodenblech	Bottom plate	Lamierino	Deksel	
28.1	KA-008-009	1	Winkelkerzenstecker	Spark-plug socket			
			SAE; entstört				
28.2	KA-008-008	1	Zündkerze, nicht entst.	spark			
29	KD-003-050	1	Folienkleber	Label	Autoadesivo	Dekal	

\*B&S

 Vor Inbetriebnahme Bedienungsanleitung und Sicherheitshinweise  
 Before starting the equipment read the owners manual and follow  
 instructions and safety precautions.  
 Avant l'utilisation lire attentivement le  
 manuel d'instructions et les  
 précautions de sécurité.

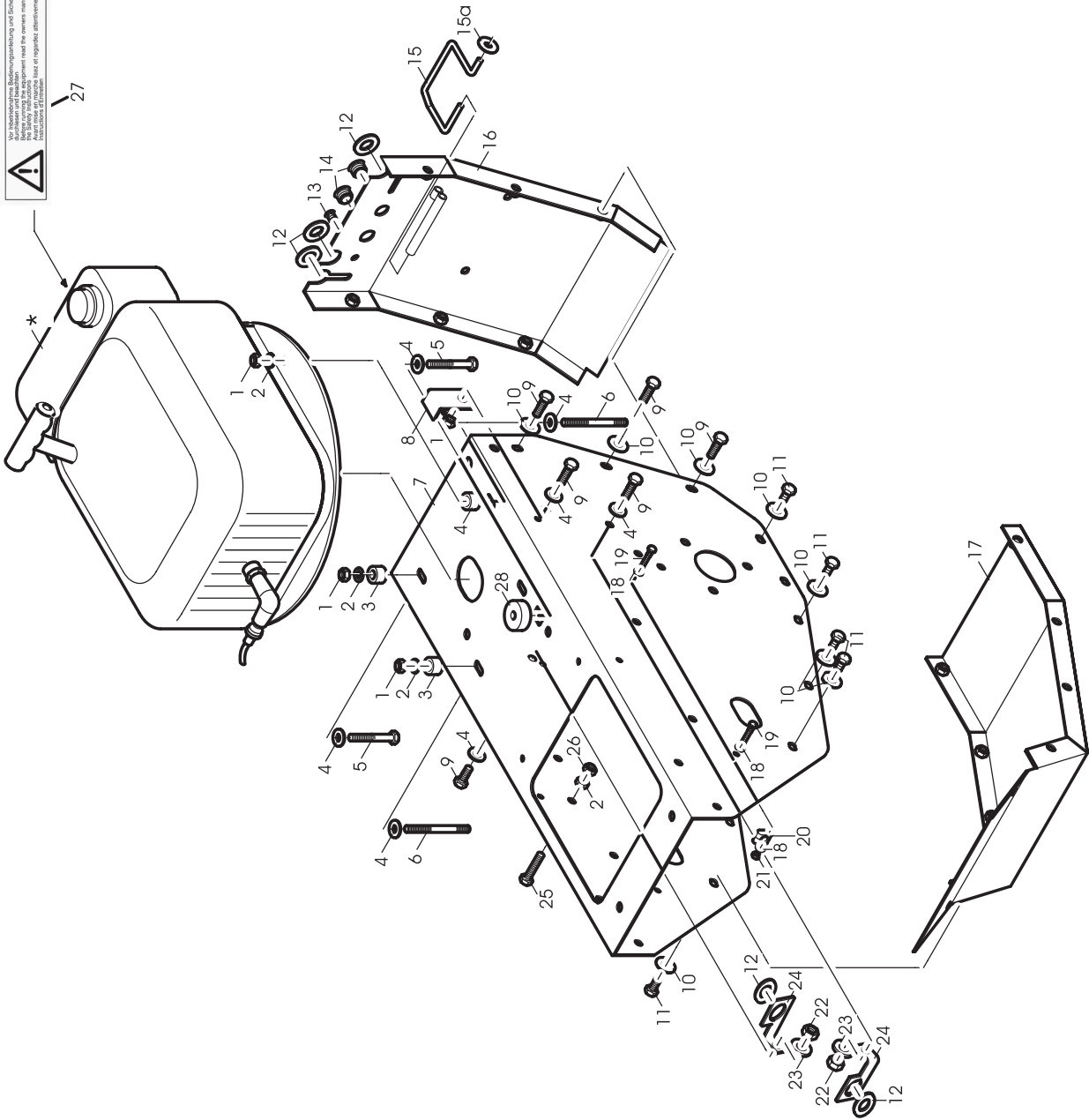

\* Motoren über Fachhandel beziehen  
 Honda



Pos.-Nr. Rep.	Bestellnummer Réfrence	Anzahl Qté.	Bezeichnung	Désignation	Description	Descrizione	Benevnelse	Bemerkung Remarks Osservazione Bemerkninger
Pos.	Article number	Quant.						
Pos.	Nr. codice	Q.tà						
Bilde-Nr.	Bestillings-Nr	Antall						
1	HR-010-005z	7	Sechskantmutter	écrou à six pans	Hexagon nut	Dado esagonale	Sekskantmutter	M 8
2	HW-010-007z	3	Scheibe	Rondelle	Washer	Rondella	Skive	B 8,4
3	DC--181-041z	3	Hülse	Douille	Spacer tube	Boccola	Hylse	
4	HW-050-007z	9	Scheibe	Rondelle	Washer	Rondella	Skive	Ø 8,4
5	HO-010-090z	3	Sechskantschraube	Vis à six pans	Hexagon bolt	Vite esagonale	Sekskantskrue	M 8 x 55
6	DC-081-013	2	Stiebolzen	Boulon	Pin	Bullone	Bolt	
7	AD-350-146-3000	1	Gehäuse	Arbre	Housing	Scatola	Hus	
8	AD-350-143g	1	Stütze	Support	Bracket	Supporto	Støtte	
9	HO-020-083z	11	Sechskantschraube	Vis à six pans	Hexagon bolt	Vite esagonale	Sekskantskrue	M 8 x 20
10	HW-060-007	14	Scheibe	Rondelle	Washer	Rondella	Skive	A 8,4
11	HO-020-082z	8	Sechskantschraube	Vis à six pans	Hexagon bolt	Vite esagonale	Sekskantskrue	M 8 x 16
12	KO-001-023	5	Kabelfülle, schwarz	Guide noire	Grommet black	Bussola di passaggio nero	Gjennomføring sort	
13	HJ-010-189	3	Lamellenstopfen, rund	Bouchon	Cap	Tappo	Tappo	8 – 9mm
14	HJ-010-188	2	Lamellenstopfen, rund	Bouchon	Cap	Tappo	Tappo	15 – 18,4mm
(15)	HI-040-016z	1	Rastfeder	Ressort d'encliquétage	Positioning spring	Molla arresto	Fjaer	
15a	HU-060-003	1	Scheibe	Rondelle	Washer	Rondella	Skive	
16	AD-350-142-3000	1	Heckblech	Tôle d'arrière	Rear cover	Lamiera posteriore	Bakre deksel	
17	AD-350-141-3000	1	Bodenblech	Fond en tôle	Bottom plate	Lamierino	Deksel	
18	HW-010-002z	4	Scheibe	Rondelle	Washer	Rondella	Skive	A 5,3
19	HO-020-032z	2	Sechskantschraube	Vis à six pans	Hexagon bolt	Vite esagonale	Sekskantskrue	M 5 x 25
20	KO-001-124	2	Zugentlastungsschelle	écrou de sûreté	Strain relief shackle	Dado autobloccante	Låsemutter	7,5 – 8,5
21	HR-030-003z	2	Sicherungsmutter	écrou à six pans	Locknut	Dado esagonale	Sekskantmutter	M 5
22	HR-010-006z	3	Sechskantmutter	Rondelle	Hexagon nut	Rondella	Skive	M 10
23	HW-050-009z	4	Scheibe	Equerre	Washer	Angolare	Vinkel	Ø 10,5
24	DA-240-420	2	Führungswinkel	Vis à six pans	Hexagon bolt	Vite esagonale	Sekskantskrue	M 8 x 40
25	HO-020-087z	1	Sechskantschraube	écrou de sûreté	Locknut	Dado autobloccante	Låsemutter	M 8
26	HR-030-005z	1	Sicherungsmutter	Autocollant	Lable	Autoadesivo	Dekal	
27	KD-003-050	1	Folienkleber	Douille	Spacer tube	Boccola	Hylse	
28	DC--321-034z	1	Hülse					

(N)





(I)

(GB)

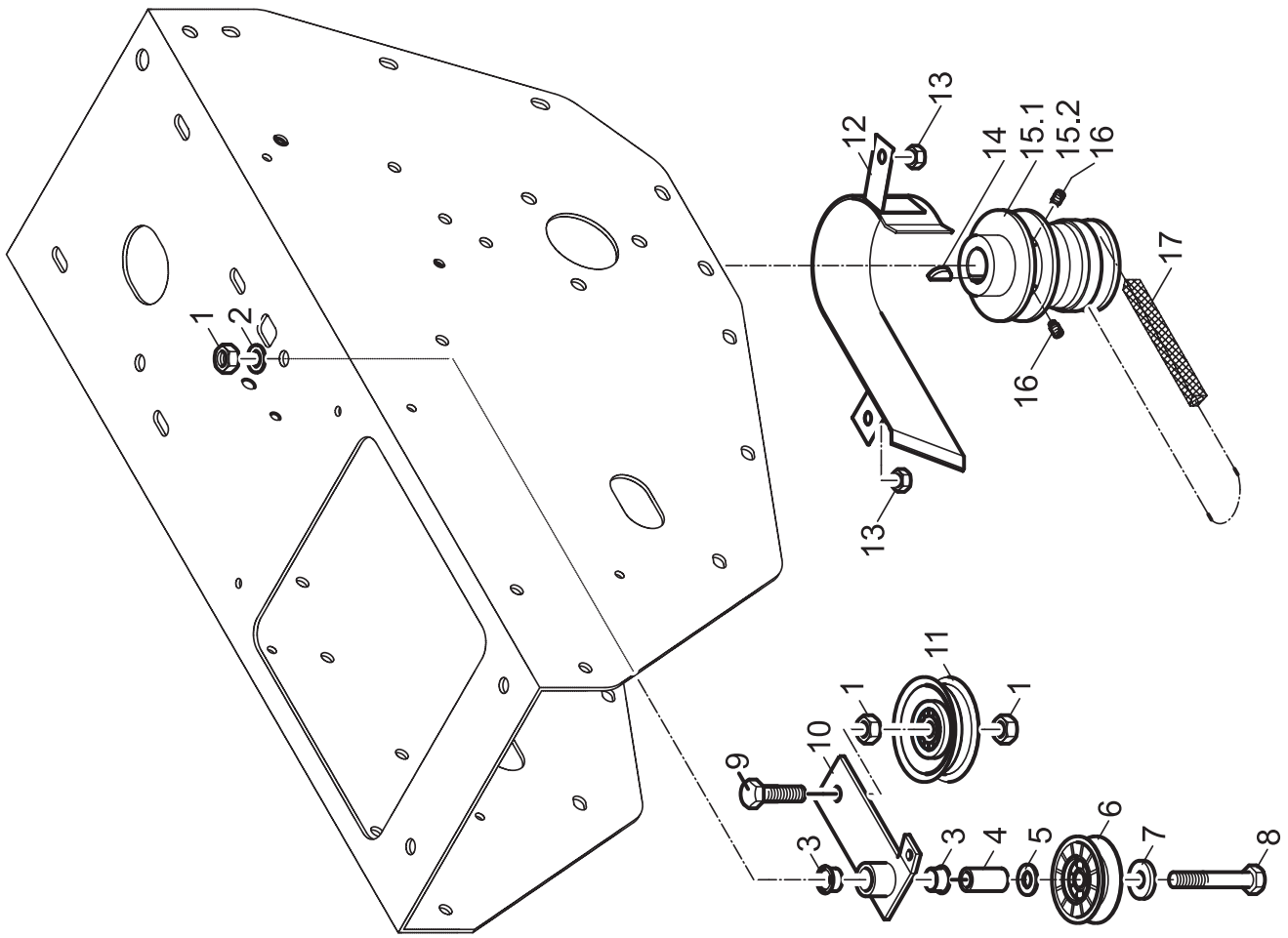



(F)

(D)

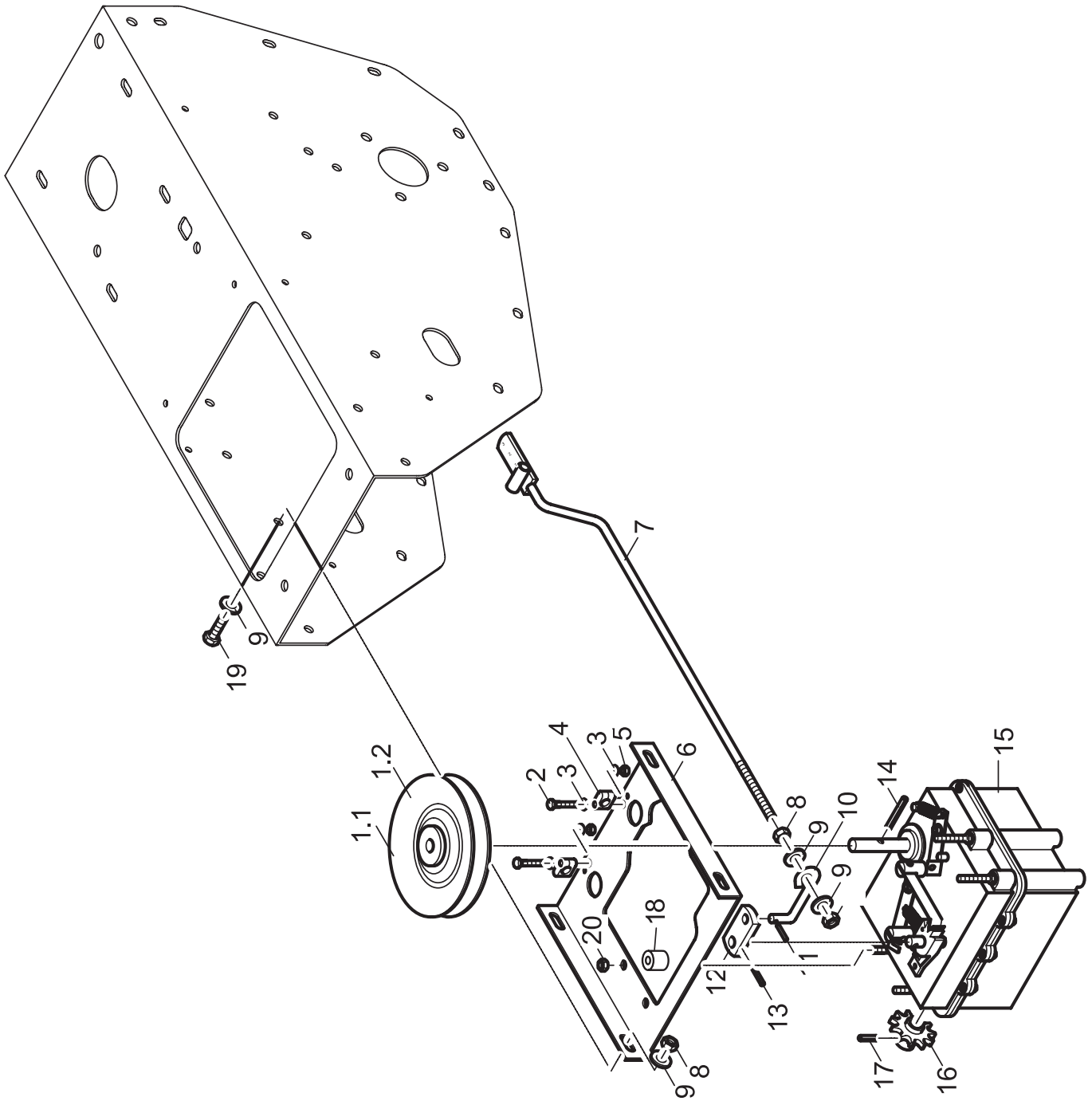







Pos.-Nr. Rep.	Bestellnummer Réfrence	Anzahl Qté.	Bezeichnung	Désignation	Description	Descrizione	Benevnelse	Bemerkung Remarque
Pos. Pos.	Article number Nr. codice	Quant. Q.tà						Remarks Osservazione Bemerkninger
Bilde-Nr.	Bestillings-Nr	Antall						
1	HR-010-006z	6	Sechskantmutter	écrou à six pans	Hexagon nut	Dado esagonale	Sekskantmutter	M 10
2	HW-020-009z	1	Scheibe	Rondelle	Washer	Rondella	Skive	Ø 10,5
(3)	HJ-021-011	2	Bundbuchse	Coussinet	Collar bush	Bussola flangiata	Foring	
4	DC-131-029z	1	Abstandshülse	Douille d'écartement	Spacer tube	Boccola distanziale	Avstandshylse	
5	HW-010-009z	1	Scheibe	Rondelle	Washer	Rondella	Skive	B 10,5
(6)	AZ-002-005	1	Spannrolle	Galet tendeur	Tensioning pulley	Rullo tenditore	Strammerull	
7	HW-050-009z	1	Scheibe	Rondelle	Washer	Rondella	Skive	Ø 10,5
8	HO-010-120z	1	Sechskantschraube	Vis à six pans	Hexagon bolt	Vite esagonale	Sekskantskrue	M 10 x 55
9	HO-020-115z	1	Sechskantschraube	Vis à six pans	Hexagon bolt	Vite esagonale	Sekskantskrue	M 10 x 30
10	AD-310-140z	1	Spanner	Tendeur	Tensioner	Tenditore	Strammer	
(11)	AZ-002-001	1	Spannrolle	Galet tendeur	Tensioning pulley	Rullo tenditore	Strammerull	
12	AD-350-150z	1	Keilriemenführung	Guidage de courroie	Vbelt guide	Guida cinghia	Kileremsføring	
13	HR-030-005z	2	Sicherungsmutter	écrou de sûreté	Locknut	Dado autobloccante	Låsemutter	M 8
14	KH-020-102	1	Sch.- Feder	Ressort	Spring	Molla	Fjær	5 / 32" x 5 / 8"
15.1	DX-001-093e	1	Keilriemenscheibe	Poulie	Vbelt pulley	Puleggia	Kileremskive	DW 63/55 für B&S
15.2	DX-001-094e	1	Keilriemenscheibe	Poulie	Vbelt pulley	Puleggia	Kileremskive	DW 63/55 für Honda GXV160
16	HP-022-051z	2	Gewindestift	Cheville	Slotted set screw	Spina filettata	Gjengestift	M 6 x 8
(17)	HB-170-042	1	Keilriemen	Courroie	Vbelt	Cinghia	Kilerem	

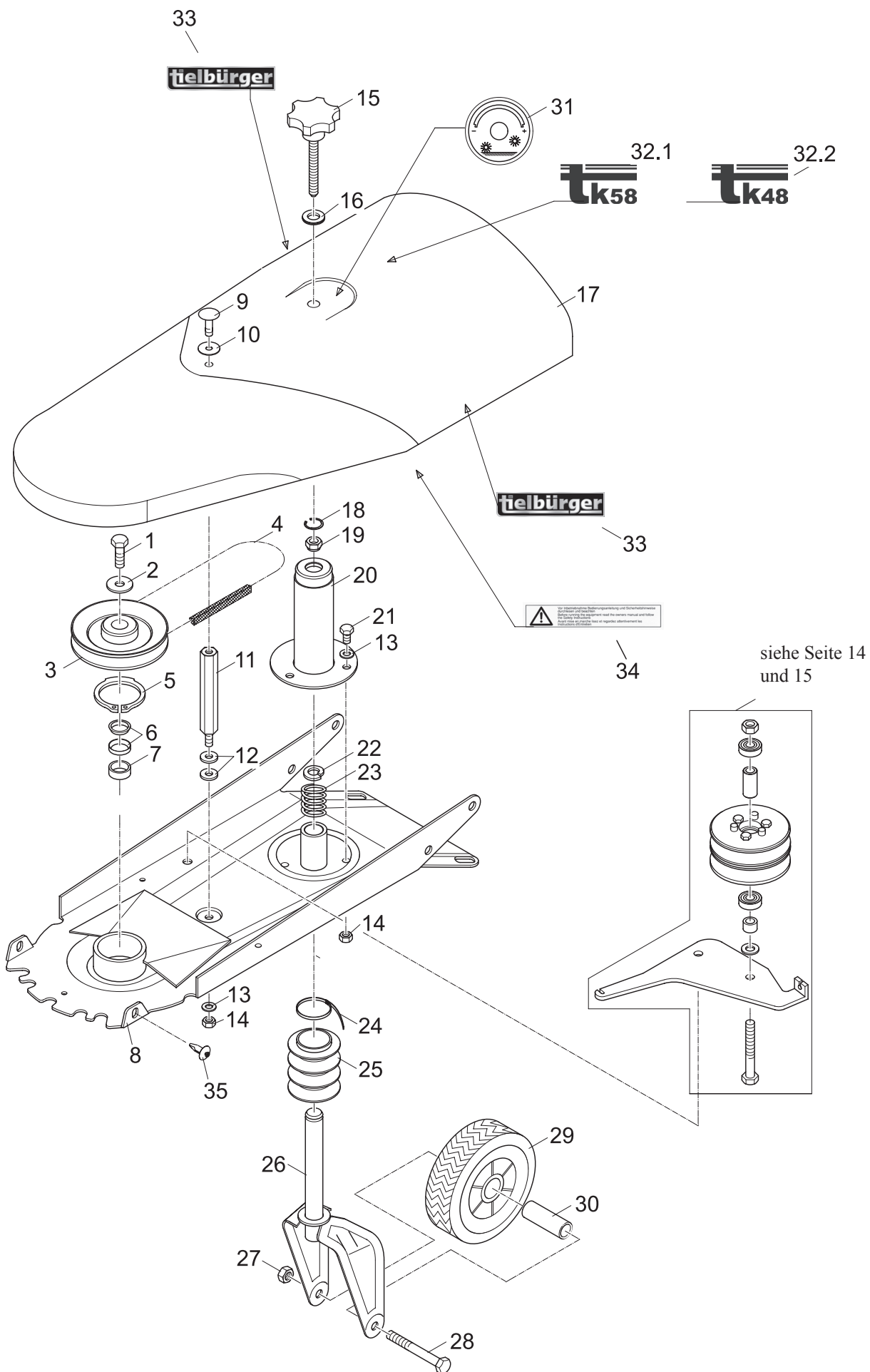

Pos.-Nr. Rep.	Bestellnummer Réfrence	Anzahl Qté.	Bezeichnung	Désignation	Description	Descrizione	Benevnlse	Bemerkung Remark Remarks Osservazione Bemerkninger
Pos. Pos. Bilde-Nr.	Article number Nr. codice Bestillings-Nr	Quant. Q.tà Antall						
(1.1)	AZ-015-032z	1	Keilriemenscheibe	Poulie	Vbelt pulley	Puleggia	Kileremskive	tk38, tk48
(1.2)	AZ-001-414	1	Keilriemenscheibe	Poulie	Vbelt pulley	Puleggia	Kileremskive	tk58
2	HO-020-032z	2	Sechskantschraube	Vis à six pans	Hexagon bolt	Vite esagonale	Sekskantskrue	M5 x 25
3	HW-010-002z	4	Scheibe	Rondelle	Washer	Rondella	Skive	A 5,3
4	KO-001-123	2	Zugentlastungsschelle	Bride de décharge de tension	Strain relief shackle			5,5 – 6,7
5	HR-030-003z	2	Sicherungsmutter	écrou de sûreté	Locknut	Dado autobloccante	Låsemutter	M 5
6	DA-240-404-9005	1	Konsole	Embase	Bracket	Mensola	Feste	
7	AD-350-144z	1	Schaltstange	Bâton	Rod	Pertica		
8	HR-010-005z	6	Sechskantmutter	écrou à six pans	Hexagon nut	Dado esagonale	Sekskantmutter	M 8
9	HW-050-007z	10	Scheibe	Rondelle	Washer	Rondella	Skive	A 8,4
10	DC-060-069	1	Verstellhebel	Levier de réglage	Adjusting lever	Leva di regolazione	Stillehendel	
11	HZ-010-076z	1	Splint	Goupille	Cotter pin	Copiglia	Splint	3,2 x 20
12	DB-570-028z	1	Hebel	Levier	Lever	Leva	Hendel	
13	HX-010-142	1	Spannstift	Goupille de serrage	Spring pin	Spina elastica	Spannstift	4,0 x 24
14	HX-010-216	1	Spannstift	Goupille de serrage	Spring pin	Spina elastica	Spannstift	5,0 x 40
(15)	AZ-016-022	1	Radantrieb Getriebe	Boîte de vitesses	Gear drive	Trasmmissione	Gear	
(16)	AD-350-145e	1	Kettenrad	Roue de chaîne	Sprocket	Ruota dentata	Kjedehjul	
*(17)	HX-010-208	1	Spannstift	Goupille de serrage	Spring pin	Spina elastica	Spannstift	5,0 x 20
18	HJ-021-022	4	Rolle	Galet	pulley oder castor	Rullo	Rull	
19	HO-020-083z	4	Sechskantschraube	Vis à six pans	Hexagon bolt	Vite esagonale	Sekskantskrue	M 8 x 20
20	HR-030-004z	4	SSicherungsmutter	écrou de sûreté	Locknut	Dado autobloccante	Låsemutter	M 6





\*Der Spannstift schützt das Getriebe vor Überlastung und schert bei zu hoher Krafeinwirkung ab.

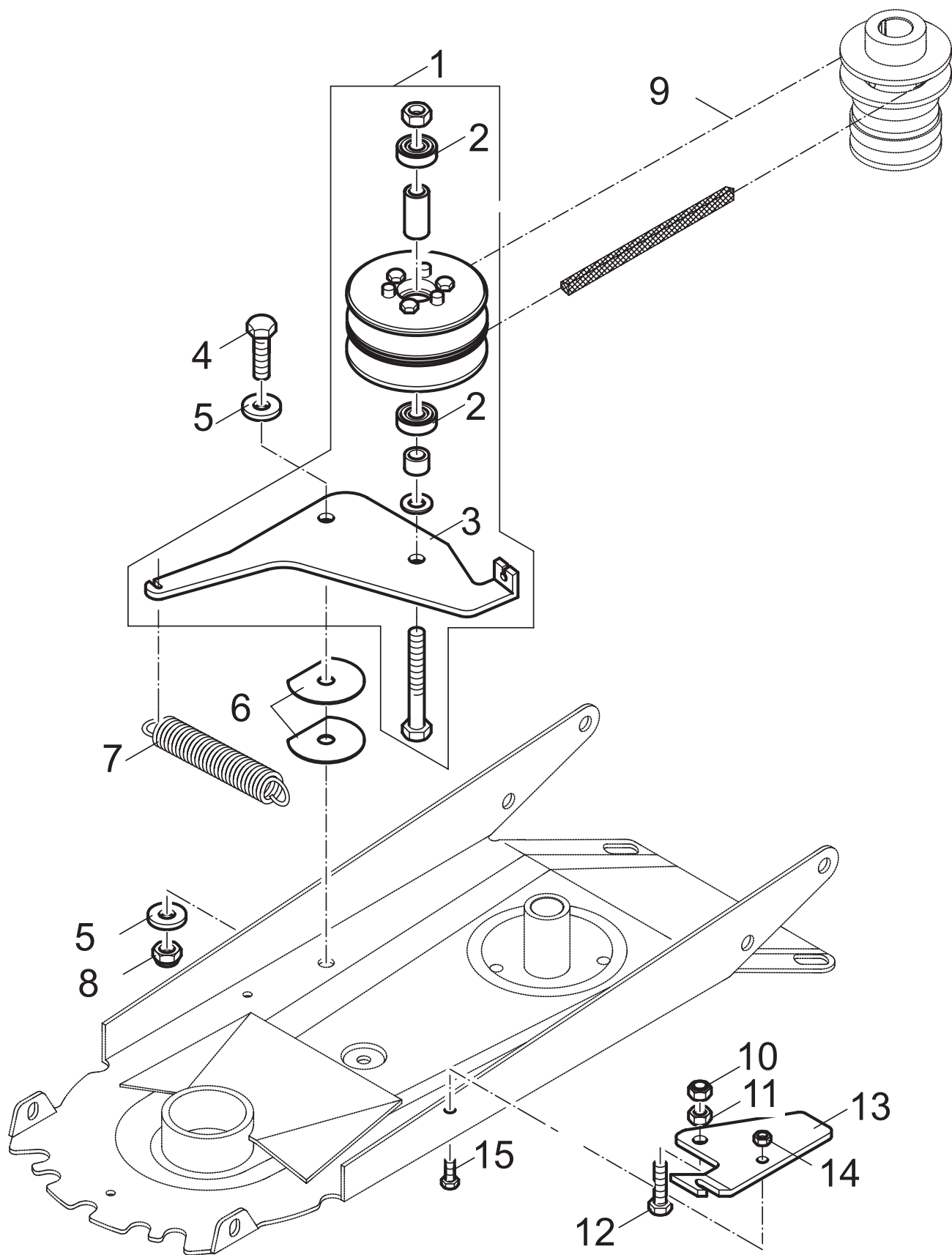







Pos.-Nr. Rep.	Bestellnummer Réfrence	Anzahl Qté.	Bezeichnung	Désignation	Description	Descrizione	Benevnelse	Bemerkung Remarque Remarks Osservazione Bemerkninger
Pos.	Article number	Quant.						
Pos.	Nr. codice	Q.tà						
Bilde-Nr.	Bestillings-Nr	Antall						
1	HO-020-114z	1	Sechskantschraube	Vis à six pans	Hexagon bolt	Vite esagonale	Sekskantskrue	M 6 x 25
2	HW-060-009z	1	Scheibe	Rondelle	Washer	Rondella	Skive	B 10,5
3	AZ-001-380-9005	1	Keilriemenscheibe	Poulie	Vbelt pulley	Puleggia	Kileremskive	
(4)	HB-112-031	1	Keilriemen	Courroie	Vbelt	Cinghia	Kilerem	
5	HU-010-048	1	Sicherungsring	Anneau d'arrêt	Retaining ring	Seget	Semering	A 48
6	KC-001-039	1	Spannelementesatz	Pièce de serrage	Tensioning piece	Parte tenditore	Spennstykke	Ø 20 x Ø 25
7	DC-241-015	1	Abstandshülse	Douille d'écartement	Spacer tube	Boccola distanziale	Avstandshylse	
8	AD-320-145-9005	1	Stellsegment	Pièce de réglage	Shifting segment	Parte regolazione	Stillestykke	
9	HP-056-083z	1	Flachrundschrabe	Vis à tête bombée	Cut head bolt	Vite testa tonda	Flatrundskruue	M 8 x 20
10	HJ-010-082	1	Kunststoff- Scheibe	Rondelle	Washer	Rondella	Skive	
11	DV-221-016z	1	Schutzhalter	Support de protecteur	Mounting stud	Supporto protezione	Dekselfeste	
12	HW-050-007z	2	Scheibe	Rondelle	Washer	Rondella	Skive	Ø 8,4
13	HW-010-007z	4	Scheibe	Rondelle	Washer	Rondella	Skive	B 8,4
14	HR-010-005z	4	Sechskantmutter	écrou à six pans	Hexagon nut	Dado esagonale	Sekskantmutter	M 8
15	HJ-010-121	1	Ballengriff	Poignée	Handle	Leva	Handtak	
16	KO-001-103	1	Durchführungsstülle	Guide	Rubber bush	Bussola di passaggio	Gjennomføring	
17	HJ-010-185-3000	1	Keilriemenschutz	Carter de protection	Vbelt cover	Protezione cinghia	Kileremsdeksel	
18	HU-020-020	1	Sicherungsring	Anneau d'arrêt	Retaining ring	Seget	Semering	M 10
19	HR-030-006z	1	Sicherungsmutter	écrou de sûreté	Locknut	Dado autobloccante	Låsemutter	
20	AD-330-141-9005	1	Stützradverstellung	Pièce de ajustement	Adjuster	Particolari di regolazione	Stillestykke	M 8 x 16
21	HO-020-082z	3	Sechskantschraube	Vis à six pans	Hexagon bolt	Vite esagonale	Sekskantskrue	Ø 13
22	KC-001-074	1	Spezial Scheibe	Rondelle spéciale	Special washer	Rondella speciale	Skive spesial	
(23)	HI-020-008	1	Druckfeder	Ressort de pression	Compression spring	Molla di compressione	Fjær	TSL-200-S
24	HJ-010-143	1	Kabelbinder	Collier en plastique	Strap	Legaccio		
(25)	HK-005-023	1	Faltenbalg	Bavette en caoutchouc	Rubber lip	Gomma protezione	Gummi	
26	AD-320-140z	1	Radträger	Support de roue	(wheel) carrier	Supporto ruota	Hjulholder	
27	HR-010-006z	1	Sechskantmutter	écrou à six pans	Hexagon nut	Dado esagonale	Sekskantmutter	M 10
28	HO-010-126z	1	Sechskantschraube	Vis à six pans	Hexagon bolt	Vite esagonale	Sekskantskrue	M 10 x 90
(29)	AD-320-050TS	1	Rad kpl. (Stützrad)	Rouesupport	Supporting wheel	Ruota supporto	Hjul	
30	DC-181-048z	1	Hülse	Douille	Spacer tube	Boccola	Hy/lse	
31	KD-003-085	1	Folienkleber	Autocollant	Label	Autoadesivo	Dekal	
32.1	KD-002-054	1	Folienkleber	Autocollant	Label	Autoadesivo	Dekal	
32.2	KD-002-053	1	Folienkleber	Autocollant	Label	Autoadesivo	Dekal	
33	KD-001-003	2	Folienkleber	Autocollant	Label	Autoadesivo	Dekal	
34	KD-003-002	1	Folienkleber	Autocollant	Label	Autoadesivo	Dekal	
(35)	HJ-010-182	2	Schraubniet					

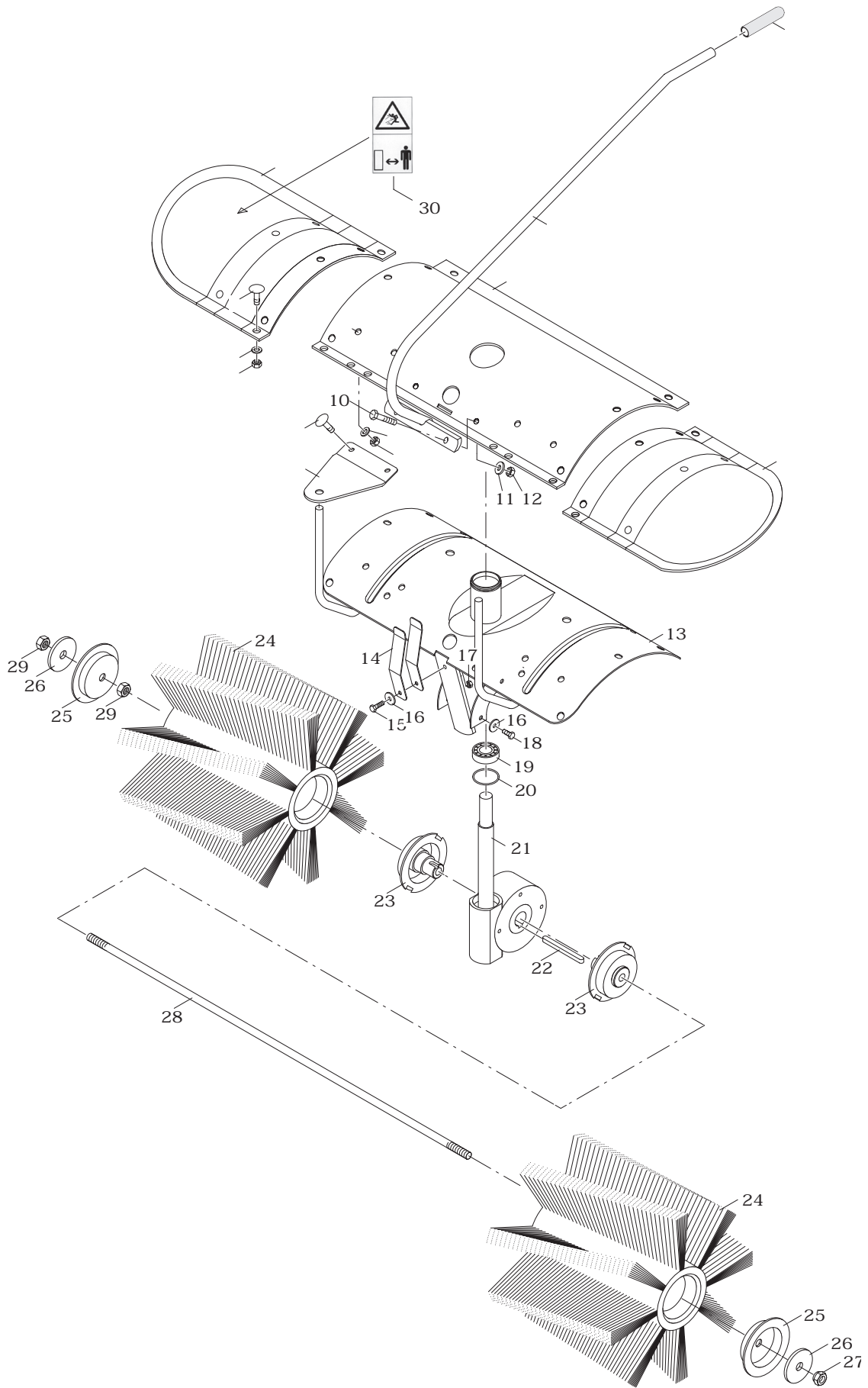



Pos.-Nr. Rep.	Bestellnummer Réfarence	Anzahl Qté.	Bezeichnung	Désignation	Description	Descrizione	Benevnelse	Bemerkung Remarque Remarks Osservazione Bemerkninger
								
1	AD-360-055 TS	1	Variator kpl.					
(2)	HA-030-001	2	Kugellager	Roulement à billes	Ball bearing	Cuscinetto a sfere	Kulelager	
3	DA-332-121-9005	1	Spanner	Tendeur	Tensioner	Tenditore	Strammer	
4	HO-020-116z	1	Sechskantschraube	Vis à six pans	Hexagon bolt	Vite esagonale	Sekskantskrue	M 10 x 30
5	HW-050-009z	2	Scheibe	Rondelle	Washer	Rondella	Skive	Ø 10,5
6	DA-180-208z	2	Scheibe	Rondelle	Washer	Rondella	Skive	
(7)	HI-010-020-9005	1	Zugfeder	Ressort de traction	Extension spring	Molla di trazione	Fjær	
8	HR-030-006z	1	Sicherungsmutter	écrou de sûreté	Locknut	Dado autobloccante	Låsemutter	M 10
(9)	HB-112-281	1	Keilriemen	Courroie	Vbelt	Cinghia	Kilerem	
10	HR-030-005z	1	Sicherungsmutter	écrou de sûreté	Locknut	Dado autobloccante	Låsemutter	M 8
11	HR-010-005z	1	Sechskantschraube	Vis à six pans	Hexagon bolt	Vite esagonale	Sekskantskrue	M 8
12	HO-020-085z	1	Sechskantschraube	Vis à six pans	Hexagon bolt	Vite esagonale	Sekskantskrue	M 8 x 30
13	DA-332-122-9005	1	Halter	Support	Stud	Supporto	Holder	
14	HR-010-004z	1	Sechskantmutter	écrou à six pans	Hexagon nut	Dado esagonale	Sekskantmutter	M 6
15	HO-020-054z	1	Sechskantschraube	Vis à six pans	Hexagon bolt	Vite esagonale	Sekskantskrue	M 6 x 16



Pos.-Nr. Rep.	Bestellnummer Réfrence	Anzahl Qté.	Bezeichnung	Désignation	Description	Descrizione	Benevnelse	Bemerkung Remarks Osservazione Bemerkninger
Pos.	Article number Nr. codice	Quant. Q.tà						
Bilde-Nr.	Bestillings-Nr	Antall						
1	HJ-010-015	1	PVC- Handgriff	Poignée	PVCgrip	Manopola PVC	Handtak	
2	AD-320-141z	1	Schwenkhebel	Levier	Selecting rod	Leva orientamento	Hendel	
2	AD-340-144z	1	Schwenkhebel	Levier	Selecting rod	Leva orientamento	Hendel	ab Ser.Nr. 12925
3	HJ-010-140-9005	1	Bürstenabdeckung, rechts	Tôle de brosses droite	Brushcover right	Coperchio spazzole dx destro (a)	Børstedeksel høyre	
4	HJ-010-133-9005	1	Bürstenabdeckung, mitte	Tôle de brosses milieu	Brushcover middle	Coperchio spazzole mezzo	Børstedeksel	
5	HJ-010-139-9005	1	Bürstenabdeckung, links	Tôle de brosses gauche	Brushcover left	Coperchio spazzole	Børstedeksel	
6	HP-056-082z	14	Flachrundschaube	Vis à tête bombée	Cut head bolt	Vite testa tonda	venstre	M 8 x 16
7	HW-010-007z	14	Scheibe	Rondelle	Washer	Rondella	Skive	B 8,4
8	HR-010-005z	14	Sechskantmutter	écrou à six pans	Hexagon nut	Dado esagonale	Sekskantmutter	M 8
9	AD-330-140z	2	Knotenblech	Tôle	Sheet steel	Lamierino	Deksel	
10	HO-010-086z	2	Sechskantschraube	Vis à six pans	Hexagon bolt	Vite esagonale	Sekskantskrue	M 8 x 40
11	HW-050-007z	2	Scheibe	Rondelle	Washer	Rondella	Skive	Ø 8,4
12	HR-030-005z	1	Sicherungsmutter	écrou de sûreté	Locknut	Dado autobloccante	Låsemutter	M 8
13	AD-310-147-9005	1	Getriebehalter	Support d'entraînement	Gear stud	Supporto trasmissione	Gearholder	
(14)	HI-030-009z	1	Blattfeder	Lame ressort	Blade spring	Molla a balestra	Bladfjær	ab Ser.Nr. 12925
15	HO-020-055z	1	Sechskantschraube	Vis à six pans	Hexagon bolt	Vite esagonale	Sekskantskrue	M 6 x 20
16	HW-030-005z	7	Scheibe	Rondelle	Washer	Rondella	Skive	R 6,6
17	HR-010-004z	1	Sechskantmutter	écrou à six pans	Hexagon nut	Dado esagonale	Sekskantmutter	M 6
18	HO-020-053z	6	Sechskantschraube	Vis à six pans	Hexagon bolt	Vite esagonale	Sekskantskrue	M 6 x 12
(19)	HA-030-005	1	Kugellager	Roulement à billes	Ball bearing	Cuscinetto a sfere	Kulelager	
20	HK-002-007	1	O- Ring	Bague	O-ring	O-ring	O-ring	38 x 2,0
(21)	AZ-016-019	1	Schneckengetriebe kpl.	Boîte de vis sans fin	Auger gear drive	Trasmissione chiocciola		
22	KH-010-013	1	Passfeder	Ressort	Parallel key	Linguetta	Kile	
23	AD-330-142-9005	2	Mitnehmer	Entraîneur	Drive pin	Trascinatore	Medbringer	
(24)	AD-090-105	1	Kehrbürstensatz	Paire de brosses	Pair of brushes	Set spazzole	Børste (2x)	
25	DA-241-024z	2	Kappe	Couvercle	Cap	Coperchietto	Kapp	
26	DA-322-007	2	Scheibe	Rondelle	Washer	Rondella	Skive	
27	HR-030-007z	1	Sicherungsmutter	écrou de sûreté	Locknut	Dado autobloccante	Låsemutter	M 12
28	DC-100-076z	1	Achse	Arbre	Axle	Asse	Aksel	
29	HR-010-007z	2	Sechskantmutter	écrou à six pans	Hexagon nut	Dado esagonale	Sekskantmutter	M 12

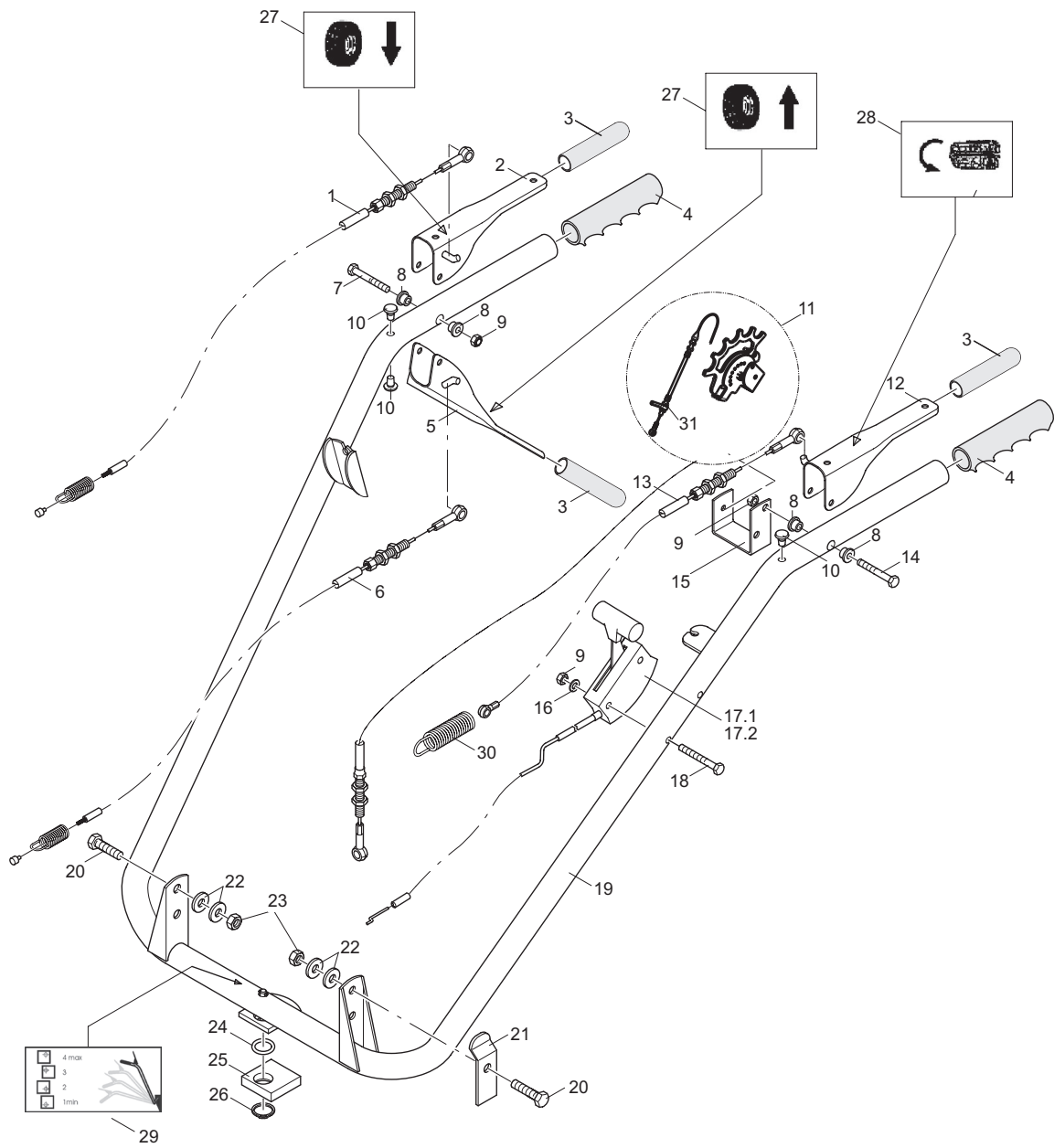

Pos.-Nr. Rep.	Bestellnummer Réfrence	Anzahl Qté.	Bezeichnung	Désignation	Description	Descrizione	Benevnlse	Bemerkung Remarque
Pos. Pos.	Article number Nr. codice	Quant. Q.tà						Remarks Osservazione
Bilde-Nr.	Bestillings-Nr	Antall						Bemerkninger
(1)	AZ-007-071	1	Bowdenzug	Câble	(Bowden) cable	Cavo	Wire	
2	AD-350-152-9005	1	Schalthebel, rechts	Levier d'embrayage, droite	Shifting lever, right	Leva comando, dx destro (a)	Girstang, høyre	
3	HJ-010-015	3	PVC- Handgriff	Poignée	PVCgrip	Manopola PVC	Handtak	Ø 14
4	HJ-010-018	2	PVC- Handgriff	Poignée	PVCgrip	Manopola PVC	Handtak	Ø 24
5	AD-350-149-9005	1	Schalthebel	Levier d'embrayage	Shifting lever	Leva comando	Girstang	
(6)	AZ-007-072	1	Bowdenzug	Câble	(Bowden) cable	Cavo	Wire	
7	HO-010-059z	1	Sechskantschraube	Vis à six pans	Hexagon bolt	Vite esagonale	Sekskantskrue	M 6 x 40
(8)	HJ-021-009	4	Buchse	Coussinet	Bush	Boccola	Foring	
9	HR-030-004z	4	Sicherungsmutter	écrou de sûreté	Locknut	Dado autobloccante	Låsemutter	M 6
10	HK-005-010	3	Zargenpuffer	Tampon d'encadrement	Rubber stop	Tampone telaio	Demper	
(11)	AZ-007-069	1	Daumenschalt. 7 Gang		Breaker			
12	AA-100-141-9005	1	Schalthebel, links	Levier d'embrayage gauche	Shifting lever left	Leva comando sx sinistro (a)	Girstang venstre	
(13)	AZ-007-017	1	Kupplungszug	Commande bowden	Clutchcable	Cavo frizione	Clutchwire	
14	HO-010-060z	1	Sechskantschraube	Vis à six pans	Hexagon bolt	Vite esagonale	Sekskantskrue	M 6 x 45
15	DA-200-683	1	Schalthebelhalter LH	Support	Stud oder bracket (Flach)	Supporto	Holder	
16	HW-010-004z	2	Scheibe	Rondelle	Washer	Rondella	Skive	B 6,4
(17.1)	AZ-006-106	1	Gashebel	Accélérateur	Throttle lever	Leva gas	Gasshendel	B&S
(17.2)	AZ-006-107	1	Gashebel	Accélérateur	Throttle lever	Leva gas	Gasshendel	Honda
18	HO-010-062z	2	Sechskantschraube	Vis à six pans	Hexagon bolt	Vite esagonale	Sekskantskrue	M 6 x 55
19	AD-350-140p9010	1	Lenker	Mancheron	Handle bars	Manubrio	Styre	
20	HO-020-086z	2	Sechskantschraube	Vis à six pans	Hexagon bolt	Vite esagonale	Sekskantskrue	M 8 x 30
21	DA-240-419p9010	1	Lenkeranschlag	Arrêt	Stopper	Arresto	Stopper / Anslag	
22	HW-050-007z	4	Scheibe	Rondelle	Washer	Rondella	Skive	Ø 8,4
23	HR-030-005z	2	Sicherungsmutter	écrou de sûreté	Locknut	Dado autobloccante	Låsemutter	M 8
24	HK-002-001	1	O- Ring	Bague	Oring	Oring	Oring	16 x 3,0
25	DB-810-013z	1	Verstellstück	Pièce de ajustement	Adjuster	Particolari di regolazione	Stillestykke	
26	HU-010-018z	1	Sicherungsring	Anneau d'arrêt	Retaining ring	Sege	Semering	A 18 x 1,2
27	KD-003-037	2	Folienkleber	Autocollant	Lable	Autoadesivo	Dekal	
28	KD-003-036	1	Folienkleber	Autocollant	Lable	Autoadesivo	Dekal	
29	KD-003-086	1	Folienkleber	Autocollant	Lable	Autoadesivo	Dekal	
(30)	HI-010-015-9005	1	Zugfeder	Ressort de traction	Extension spring	Molla di trazione	Fjær	
31	AZ-007-098	1	Bowdenzug	Câble	(Bowden) cable	Cavo	Wire	

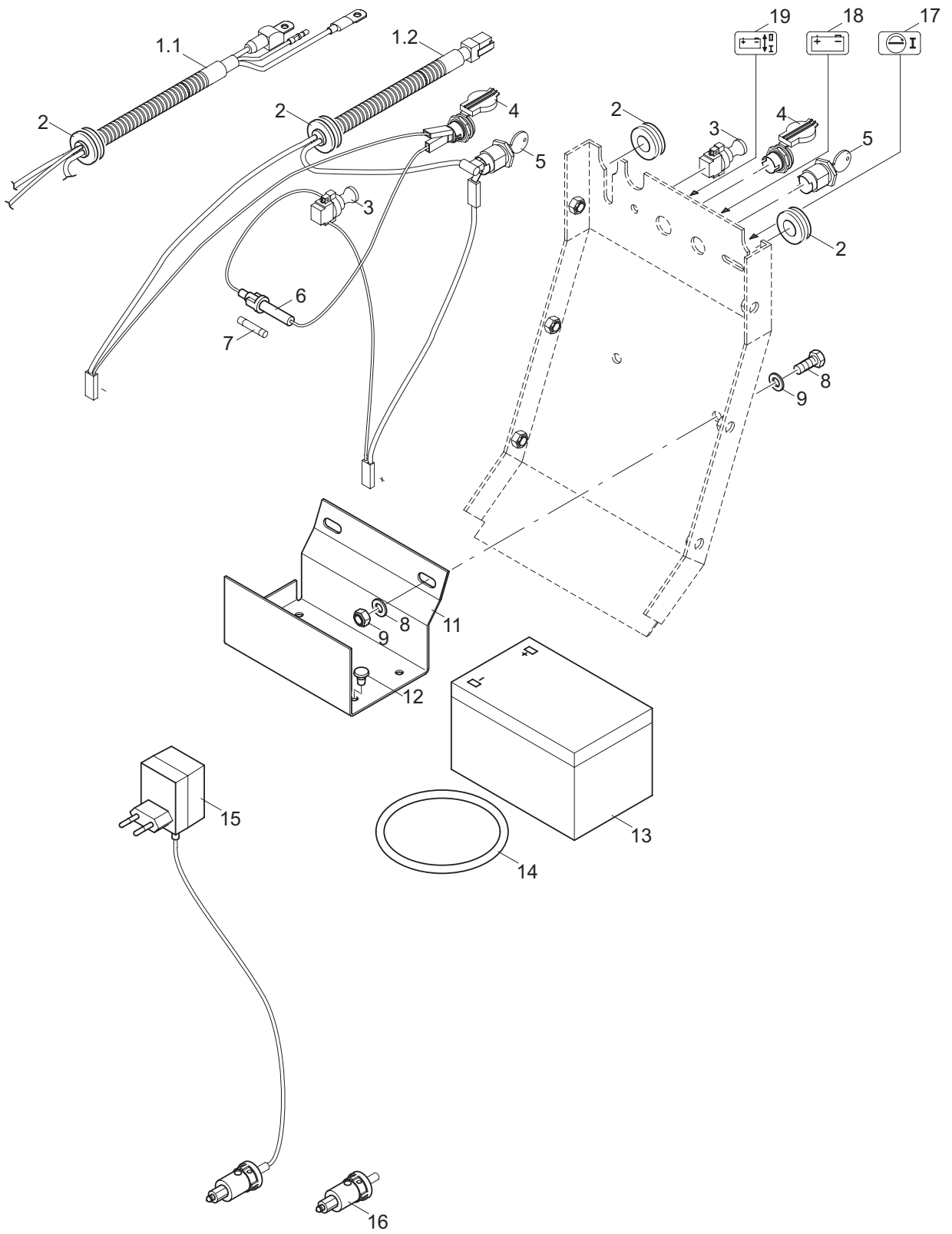

Pos.-Nr.	Bestellnummer	Anzahl	Bezeichnung	Désignation	Description	Descrizione	Benevnelse	Bemerkung
Rep.	Référence	Qté.						Remark
Pos.	Article number	Quant.						Remarks
Pos.	Nr. codice	Q.tà						Osservazione
Bilde-Nr.	Bestillings-Nr	Antall						Bemerkninger
1.1	AZ-017-032	1	Kabelbaum					
1.2	AZ-017-031	1	Kabelbaum					
2	KO-001-023	2	Kabeltülle,	Guide schwarz	Grommet noire	Bussola di passaggio black	Gjennomføring nero	sort
(3)	KO-001-068	1	Zugschalter		Pullswitch	Interruttore a tirante		
(4)	KO-001-104	1	Steckdose	Prise de courant	Socket	Presa di corrente		
5	KA-008-004	1	Schlüssel-Schalter	Commutator de la clé	Keyswitch	Chiave avviamento		
6	KO-001-024	1	Sicherungshalter	Support	Stud	Supporto	Holder	
(7)	KO-001-008	1	KFZ- Sicherung	Fusible	Fuse	Fusibile		6 x 25mm
8	HO-020-083z	2	Sechskantschraube	Vis à six pans	Hexagon bolt	Vite esagonale	Sekskantskrue	M 8 x 20
9	HW-010-007z	4	Scheibe	Rondelle	Washer	Rondella	Skive	B 8,4
10	HR-030-005z	2	Sicherungsmutter	écrou de sûreté	Locknut	Dado autobloccante	Låsemutter	M 8
11	DA-200-682z	1	Batteriehalter	Support	Stud oder bracket (Flach)	Supporto	Holder	
12	HK-005-010	4	Zargenpuffer	Tampon d'encadrement	Rubber stop	Tampone telaio	Demper	
(13)	KO-001-125	1	Batterie	Batterie	Batterie	Batteria		
14	HK-002-008	1	Rollring- Gummi		Rubber band			
(15)	AZ-017-029	1	Ladegerät	Chargeur	Chargingequipment	Caricabatteria		
16	KO-001-105	1	Stecker	Fiche	DCplug	Spina		
17	KD-003-055	1	Folienkleber	Autocollant	Lable	Autoadesivo	Dekal	
18	KD-003-056	1	Folienkleber	Autocollant	Lable	Autoadesivo	Dekal	
19	KD-003-057	1	Folienkleber	Autocollant	Lable	Autoadesivo	Dekal	
	KA-008-007	1	E- Starter kpl.	Starter électrique	Electric starter	Avv. elettrico		

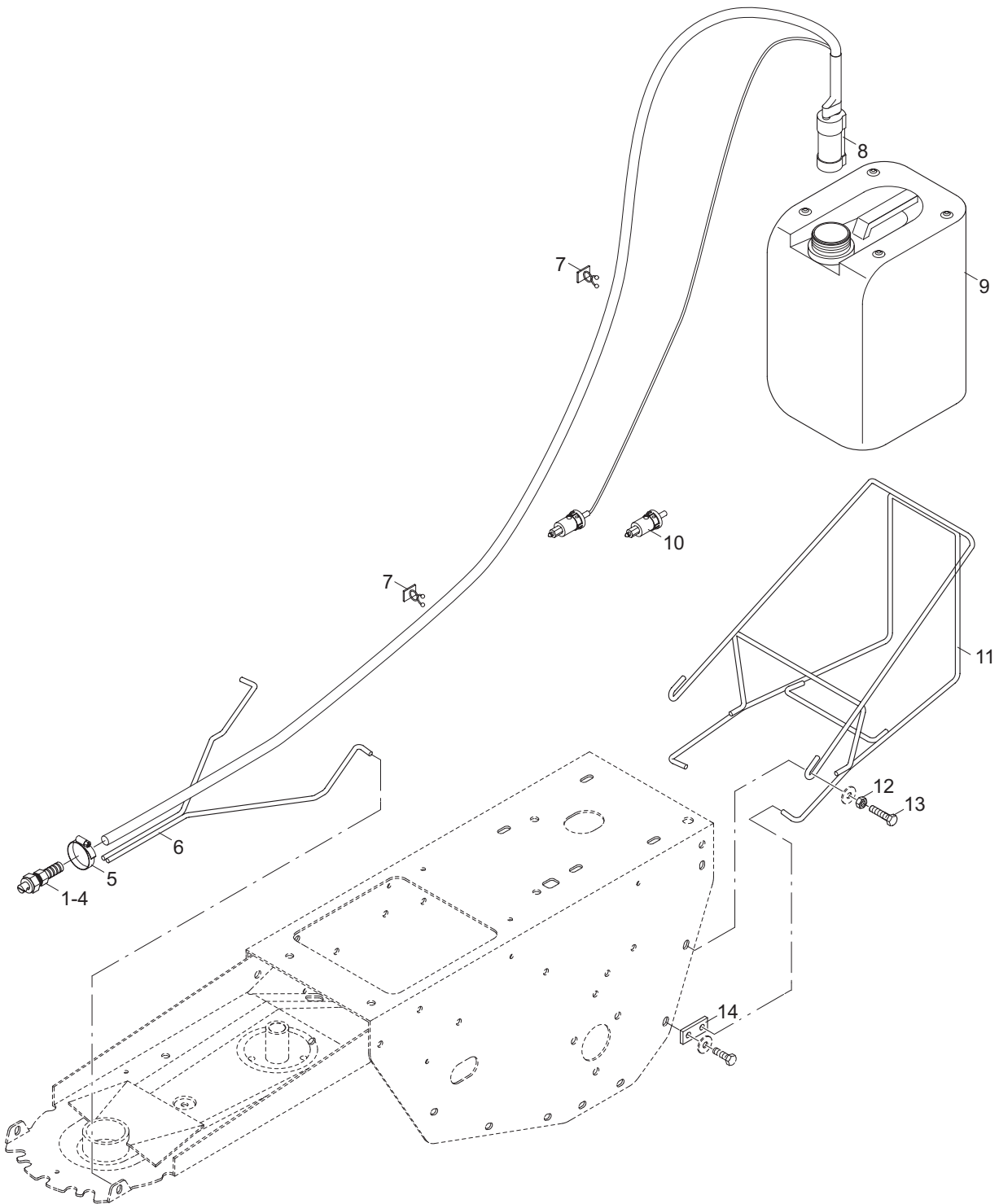



Pos.-Nr. Rep.	Bestellnummer Référence	Anzahl Qté.	Bezeichnung	Désignation	Description	Descrizione	Benevnelse	Bemerkung Remarks Osservazione Bemerkninger
Pos. Pos.	Article number Nr. codice	Quant. Q.tà		(F)	(GB)	(I)	(N)	
Bilde-Nr.	Bestillings-Nr	Antall						
1	KC-001-055	1	Düsenkörper		Jetbody	Corpo ugello		
2	KC-001-057	1	Filter	Filtere	Filter	Filtro	Filter	
3	KC-001-058	1	Düse	Gicleur	Jet	Ugello		
4	KC-001-056	1	Überwurfmutter	Ecrou d'adaptateur	Adaptor nut	Dado	Mutter	
5	KO-001-102	1	Schlauchschelle		Hoseclip			LC 161 – 25 W1
6	AD-311-141z	1	Düsenträger	Support de gicleur	Jetsupport	Supporto ugello		
7	HJ-010-116	3	Driller		Driller			
8	KO-001-071	1	Tauchpumpe „Elegant“	Pompe	Diving pump	Pompa sommersa		12V
9	HJ-010-092	1	Wasserkarister	Kanister	Réservoir	Canister	Bidone	10 ltr.
10	KO-001-105	1	Stecker	Fiche	DCplug			
11	AD-311-143z	1	Kanisterhalter	Support de réservoir	Carrier	Supporto bidone	Holder	
12	HO-020-085z	2	Sechskantschraube	Vis à six pans	Hexagon bolt	Vite esagonale	Sekskantskrue	M 8 x 30
13	DB-200-058z	2	Lasche	Tirant	Tongue	Staffa	Feste	
14	HR-010-005z	2	Sechskantmutter	écrou à six pans	Hexagon nut	Dado esagonale	Sekskantmutter	M 8

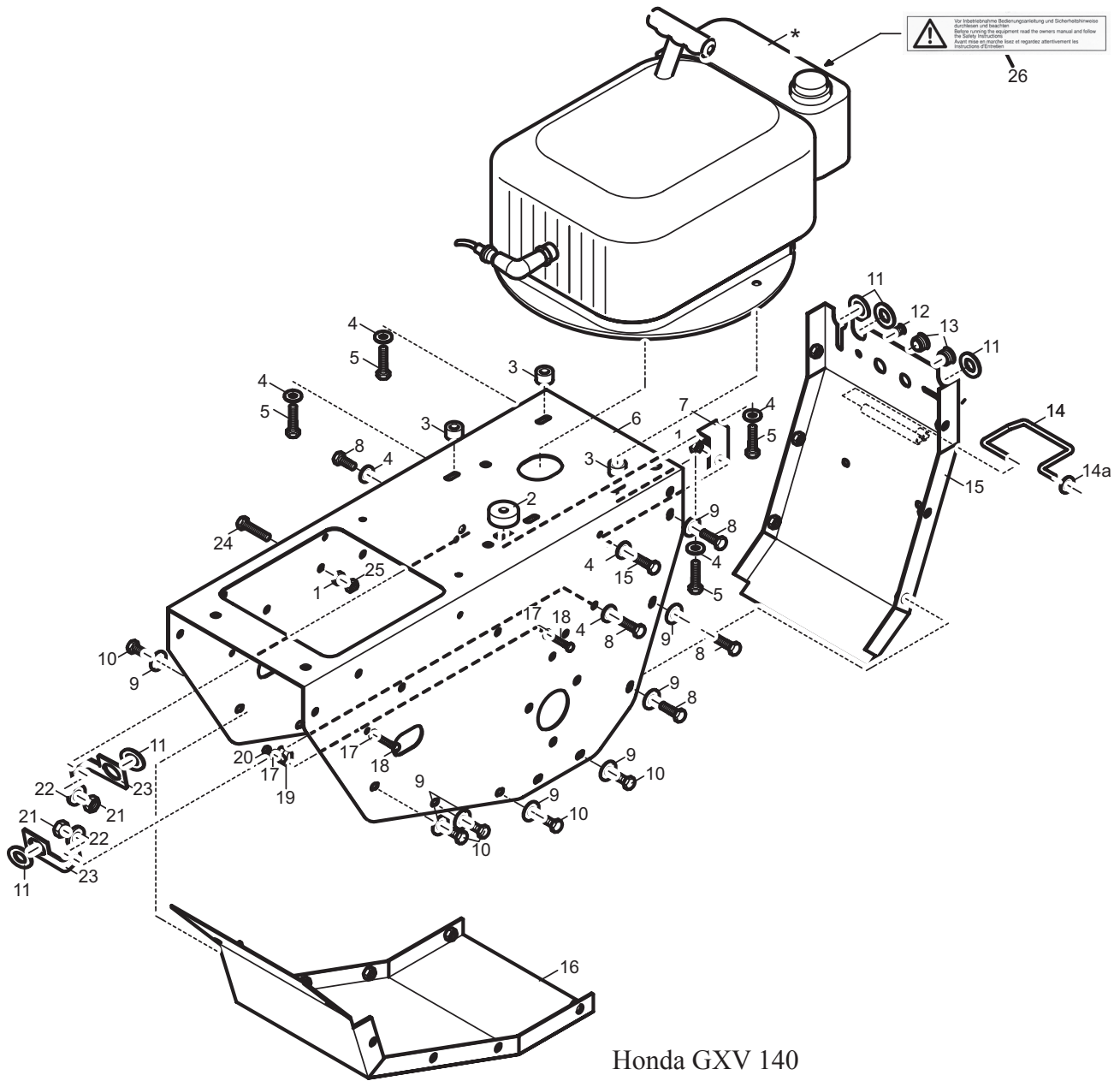

Pos.-Nr. Rep.	Bestellnummer Réfrence	Anzahl Qté.	Bezeichnung	Désignation	Description	Descrizione	Benevnelse	Bemerkung Remarque Remarks Osservazione Bemerkninger
Pos. Pos.	Article number Nr. codice	Quant. Q.tà						
Bilde-Nr.	Bestillings-Nr	Antall						
1	HR-010-005z	4	Sechskantmutter	écrou à six pans	Hexagon nut	Dado esagonale	Sekskantmutter	M 8
2	DC-321-034z	1	Hülse	Douille	Spacer tube	Boccola	Hylse	
3	DC-181-041z	3	Hülse	Douille	Spacer tube	Boccola	Hylse	
4	HW-050-007z	9	Scheibe	Rondelle	Washer	Rondella	Skive	Ø 8,4
5	HO-090-305z	4	Zollschraube	Vis au pouce	Whitworthbolt	Vite in pollici	Skru	
6	AD-350-146-3000	1	Gehäuse	Arbre	Housing	Scatola	Hus	
7	AD-350-143g	1	Stütze	Support	Bracket	Supporto	Støtte	
8	HO-020-083z	11	Sechskantschraube	Vis à six pans	Hexagon bolt	Vite esagonale	Sekskantskrue	M 8 x 20
8,4	9		HW-060-007	14	Scheibe	Rondelle	Washer	Rondella
10	HO-020-082z	8	Sechskantschraube	Vis à six pans	Hexagon bolt	Vite esagonale	Sekskantskrue	M 8 x 16
11	KO-001-023	5	Kabeltülle, schwarz	Guide noire	Grommet black	Bussola di passaggio nero	Gjennomføring sort	
12	HJ-010-189	3	Lamellenstopfen, rund	Bouchon	Cap	Tappo		8 – 9mm
13	HJ-010-188	2	Lamellenstopfen, rund	Bouchon	Cap	Tappo		15 – 18,4mm
(14)	HI-040-016z	1	Rastfeder	Ressort d'encliquétage	Positioning spring	Molla arresto	Fjaer	
14a	HU-060-003	1	Scheibe	Rondelle	Washer	Rondella	Skive	
15	AD-350-142-3000	1	Heckblech	Tôle d'arrière	Rear cover	Lamiera posteriore	Bakre deksel	
16	AD-350-141-3000	1	Bodenblech	Fond en tôle	Bottom plate	Lamierino	Deksel	
17	HW-010-002z	4	Scheibe	Rondelle	Washer	Rondella	Skive	A 5,3
18	HO-020-032z	2	Sechskantschraube	Vis à six pans	Hexagon bolt	Vite esagonale	Sekskantskrue	M 5 x 25
19	KO-001-124	2	Zugentlastungsschelle	écrou de sûreté	Strain relief shaekle	Dado autobloccante	Låsemutter	7,5 – 8,5
20	HR-030-003z	2	Sicherungsmutter	écrou à six pans	Locknut	Dado esagonale	Sekskantmutter	M 5
21	HR-010-006z	2	Sechskantmutter	Rondelle	Washer	Rondella	Skive	M 10
22	HW-050-009z	5	Scheibe	Equerre	Slide	Angolare	Vinkel	Ø 10,5
23	DA-240-420	2	Führungswinkel	Vis à six pans	Hexagon bolt	Vite esagonale	Sekskantskrue	M 8 x 40
24	HO-020-087z	1	Sechskantschraube	écrou de sûreté	Locknut	Dado autobloccante	Låsemutter	M 8
25	HR-030-005z	1	Sicherungsmutter	Autocollant	Label	Autoadesivo	Dekal	
26	KD-003-050	1	Folienkleber	Rondelle de ressort	Spring washer	Rondella elastica	Sprengskive	
27	HU-060-003	1	Federscheibe					