

# FACTORYCAT<sup>®</sup>

Industrial Cleaning Equipment

# MAG-HID

29" - 34" Scrubbers



A COMPLETE FAMILY OF INDUSTRIAL CLEANING EQUIPMENT



# KEY FEATURES



**Machine Control Panel** uses off-the-shelf toggle and marine duty switches and features universal icons which simplifies training.



**Vacuum Muffler** allows machine to consistently achieve as low as 62 dB for noise sensitive applications while thoroughly drying the floor.



**Squeegee Adjustments made simple** with quick change squeegee latch allows toolless maintenance and 4-sided squeegee blade.

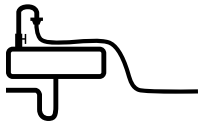

**Front Fill System** features a retractable hose for easy filling on standard sink-faucets.

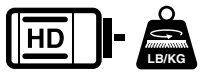

**High Performance motors and down pressure** provides an unmatched standard of cleaning.



## INDUSTRIES

Fabrication Shops

Warehouses

Machine Shops

Automotive Shops

Aviation

Food Packaging

Beverage Distribution

Sports Arenas

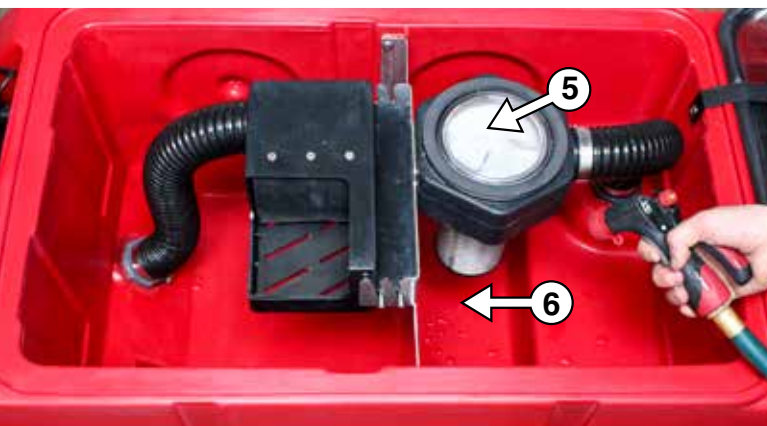

## EASE OF MAINTENANCE

- 1 Tip Back "Clam Shell" Design
- 2 Access to Batteries
- 3 Access to Scrub Motors
- 4 Access to Solution Filter
- 5 White Vacuum Filter Access
- 6 Full Recovery Tank Access

# VIEW INSIDE

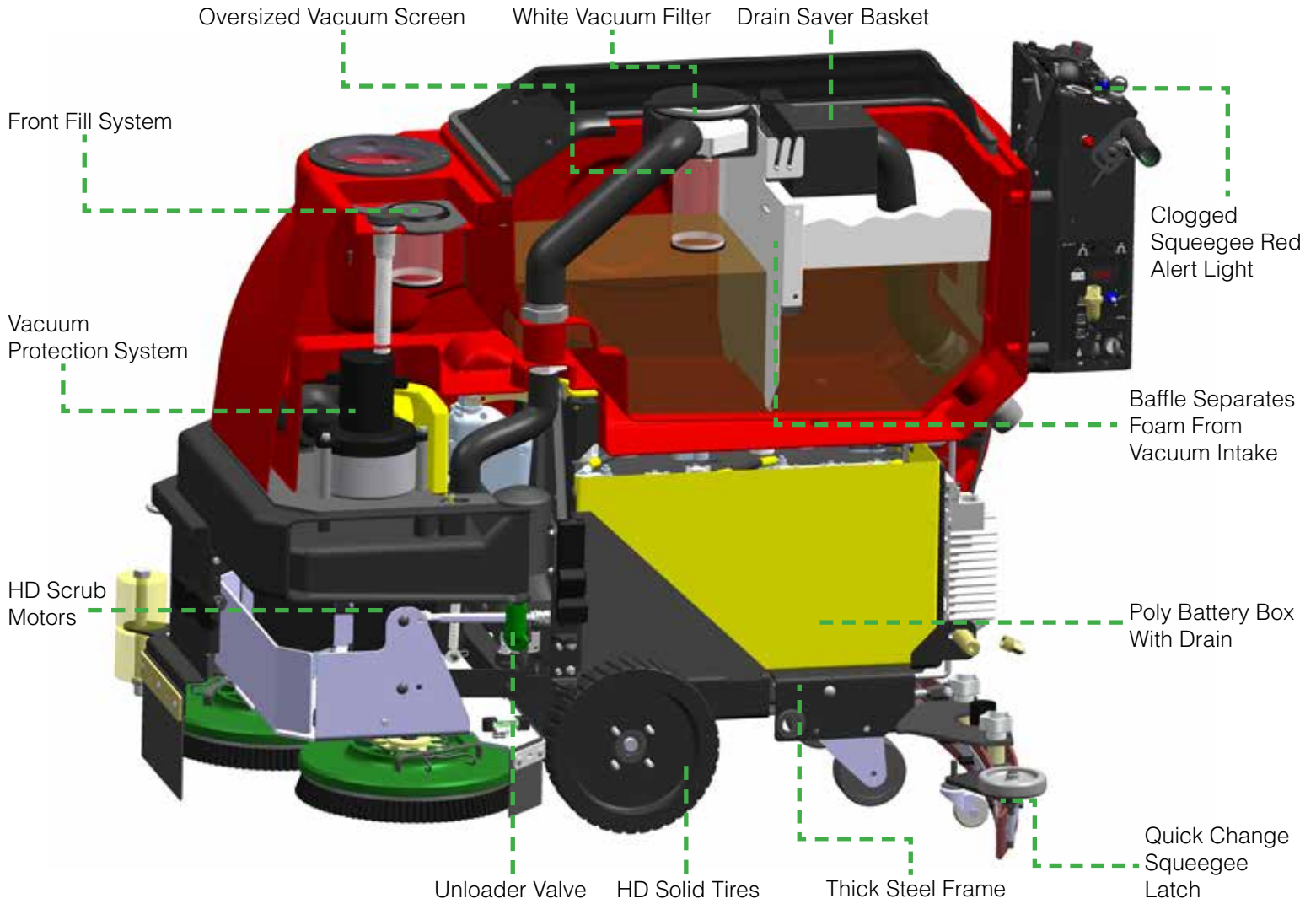

## TWO SCRUB SYSTEMS TO CHOOSE FROM

### DISK

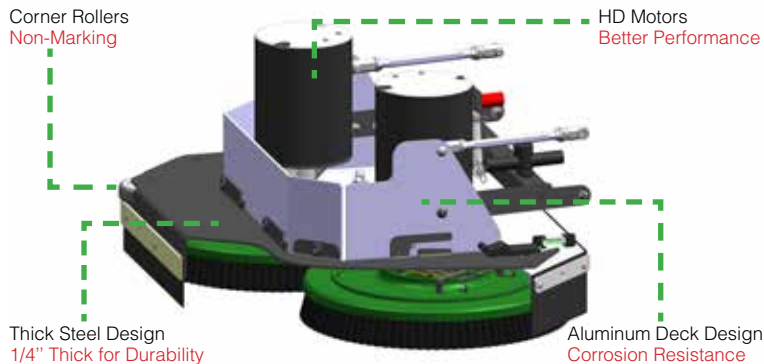

#### BENEFITS

- Brush / Pad Selection
- Lowest Maintenance Cost
- Gimballed Drivers Improves Cleaning On Irregular Floors
- Brushes Individually Driven For Unmatched Performance

### CYLINDRICAL

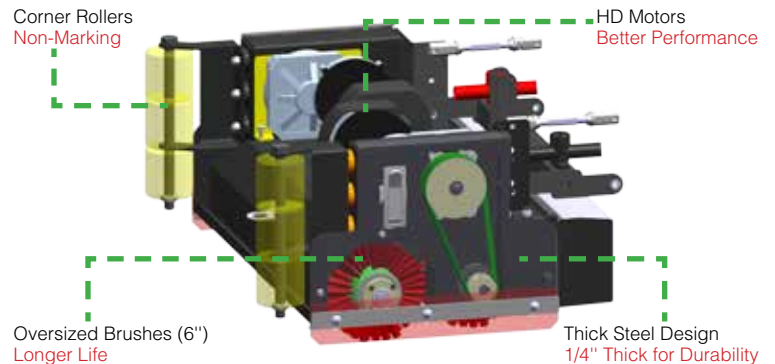

#### BENEFITS

- Eliminates Dust Mopping
- Scrub & Sweep Simultaneously
- Superior Grouted Tile Cleaning

# CALL FOR A DEMONSTRATION

☎ **800-634-4060**  
 🌐 **(+001)-262-681-3583**  
 🌐 **www.factorycat.com**

Since 1986, our family owned company has been designing, building and supporting the best in floor maintenance equipment. Our **FACTORYCAT** brand services the world with unsurpassed industrial cleaning equipment, continually exceeding expectations and setting the industry bar that much higher.

We've built our reputation by providing the highest value machines and providing local support via 425 distributors in over 42 different countries.

## AUTHORIZED DISTRIBUTOR



**Manufactured By:**  
 R.P.S. Corporation  
 1711 South Street  
 Racine, Wisconsin 53404 (USA)  
 Phone: (800) 634-4060  
 International: (+001) 262-681-3583  
 www.factorycat.com

Copyright R.P.S. Corporation 2016. All rights reserved. Since our policy is one of constant improvement, all specifications are subject to change without notice.

### BODY CONSTRUCTION / DIMENSIONS

Tank Material:	Poly 3/8" (10 mm)
Chassis Construction:	3/16" Steel (5 mm) Powder Coated Steel
Front Wheels (Diameter x Width):	(2x) 12" x 2.75" ([2x] 31 x 7 cm) - Solid Black
Rear Casters (Diameter x Width):	(2x) 5" x 2" ([2x] 13 x 5 cm) - Non-Marking Grey
Size (L x W x H):	55" x 26" x 40" (140 x 66 x 102 cm)
Weight (w/o Batteries):	441 - 481 lbs (200 - 218 kg)
Weight (w/ 315 ah Batteries):	775 - 825 lbs (352 - 374 kg)

### BRUSH / PAD SYSTEM

Disk Dimensions:	30" - (2x) 15" Diameter (76 - [2x] 38 cm)
<small>Includes Jaws with Rollers for Wall Protection</small>	34" - (2x) 17" Diameter (86 - [2x] 43 cm)
Disk Motor:	(2x) 1.0 hp / 350 rpm ([2x] 746 watts)
Disk Brush Speed:	350 rpm
Cylindrical Dimensions:	29" - (2x) 6" x 27" (74 - [2x] 15 x 69 cm)
<small>6" Diameter Brush</small>	33" - (2x) 6" x 31" (84 - [2x] 15 x 79 cm)
Cylindrical Motor:	(2x) 1.0 hp / 350 rpm ([2x] 746 watts)
Cylindrical Brush Speed:	750 rpm
Actuator Rating:	500 lbs (227 kg)
Brush Pressure Settings:	(5) with Auto Adjust

### POWER SYSTEM

System Voltage:	24 VDC
Standard Battery:	315 ah WET
Optional Battery:	360 ah WET / 335 ah AGM*
<small>*Includes Onboard Charger</small>	
Run Time:	Up to 5.0 Hours**
<small>**Run times are based on continuous scrubbing run times.</small>	
Charger:	120VAC / 60 Hz Input - 24VDC / 30 amp Output

### DRIVE SYSTEM:

Power:	0.75hp - All Gear / Sealed (559 watts)
Forward Speed:	0 - 290 ft/min / 0 - 3.3 mph (0 - 88 m/min / 0 - 5 km/h)
Scrubbing Speed:	0 - 229 ft/min / 0 - 2.6 mph (0 - 70 m/min / 0 - 4 km/h)
Reverse Speed:	0 - 202 ft/min / 0 - 2.3 mph (0 - 62 m/min / 0 - 4 km/h)

### SOLUTION / RECOVERY SYSTEMS:

Solution Tank Capacity:	30 Gallons (114 liters) - w/ Graduated Site Tube
XL Tank Option Solution Capacity:	35 Gallons (133 liters) - w/ Graduated Site Tube
Solution Flow / Filter:	0 - 1.0 GPM / Stainless Inline (0 - 4 LPM)
Recovery Tank Capacity:	32 Gallons (121 liters) - 1.5" diameter Drain Hose
XL Tank Option Recovery Capacity:	37 Gallons (140 liters) - 1.5" diameter Drain Hose
Demisting Chamber:	1.25 Gallons (5 liters)
Drain Saver:	30 cubic inches (492 cubic cm)
Vacuum Power:	0.8 hp / 3 Stage (640 watts)
Vacuum Specs (Water Lift / Airflow):	68" / 72 cfm (173 cm / 2 cm/m)
Squeegee:	42" Curved w/ 4-sided Rear Blade & Quick Change Latch Optional - 36" Squeegee

### GENERAL:

Cleaning Width:	30" & 34" - Disk (76 & 86 cm) 29" & 33" - Cylindrical (64, 74, 84 cm)
Decibels:	62 dB
Productivity - Theoretical:	Up to 31,915 sqft (2,965 sqm)***
<small>***Productivity is based off of ISSA 2010 Cleaning Times</small>	
Productivity - Practical:	Up to 14,851 sqft (1,380 sqm)***
<small>***Productivity is based off of ISSA 2010 Cleaning Times</small>	